

V. 2. FIRE SERVICE OPERATIONS - COMPARTMENT FIRES & TACTICAL VENTILATION

Chapter 1 - The Fire

1 Combustion

When a candle burns, the wax melts. The liquid is drawn up the wick, where it turns into a flammable vapour. It is this vapour which burns, forming the flame.

In the same way, in a fire in a compartment, it is useful to think of all the combustible materials (the fuel) as being sources of flammable gases. These gases, which need not necessarily ignite, are generated when the fuel is heated. Initially the gases result from the boiling off and decomposition (pyrolysis) of hydrocarbons, such as the resin in wood. Eventually, if they get hot enough, the remaining solids, such as charcoal in the case of wood, will themselves start to burn.

These gases rise in a plume

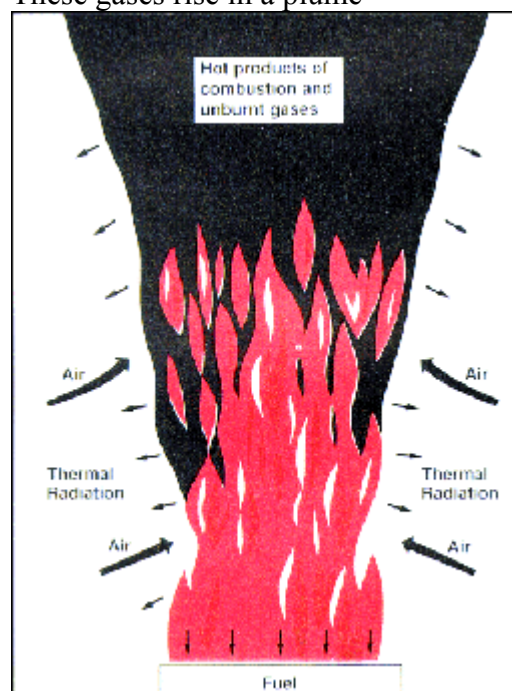

(Figure 1.1), and mix with air. If the gas/air mixture is correct, any given ignition source (eg a flame or spark) will trigger the combustion process which will rapidly become self-sustaining. The reactions which occur between the flammable gases and the oxygen in the air, generate large amounts of energy. This energy causes a rise in the temperature of the gases produced in the reaction (the products of combustion) and also appears as thermal radiation (heat) and visible radiation (flame).

The high gas temperatures cause a vigorous upward movement driven by buoyancy; this induces mixing with the surrounding air by a process known as entrainment.

Low down in the plume, the centre will be rich in flammable gases and this will be surrounded by an envelope of flame.

In the upper part of the plume, there is no flame. It is a rising column of smoke which consists of large amounts of entrained air, together with non-flammable products of combustion (mainly carbon dioxide and water), unburnt flammable gases and minute particles (soot). The flammable gases in the upper part of the fire are at too low a concentration to burn.

The upper part of the flame is basically unstable, producing the well-known flickering associated with fires. In general, though, the average flame height depends on the heat generated by the fire.

The hot plume radiates down on to the fuel, heating it, and so permitting the generation of flammable gases to continue. In general, there will be sufficient heat generated for the fire to spread as long as there is fuel nearby. However, during the early stages of a fire, it is not the main cause of fire spread. Nevertheless, the effect of thermal radiation can become more significant as the fire develops, as it is the cause of flashover. This is discussed later

2 Fire Growth

Rapid fire spread occurs when the flames come into contact with new sources of fuel. This fuel will then be raised to very high temperatures, will itself start to generate flammable gases very quickly and eventually ignite. However, until the hot gases in the plume have been cooled by mixing with sufficient cool air, they will also be hot enough to cause fuel to start giving off flammable gases, if they come into contact with it.

Thermal radiation from the plume is the main element in fire spread wherever there is no direct flame impingement. Surrounding objects are heated until they in turn start to give off flammable gases.

The heat from the plume also heats up the air in the compartment as well as the walls, ceiling, floor and contents. As little as one third of the heat from a compartment fire will leave the compartment as hot smoke. As the compartment temperature rises, less and less heat from the plume can be absorbed by the compartment's walls and contents. The plume gets hotter and this increases the efficiency of the combustion process. It also further heats the fuel, increasing the rate at which the gases are generated. Thus, increasing compartment temperatures will result in increased combustion, as long as there is an adequate supply of oxygen.

3 The Effects of Water

Water is a most efficient fire fighting agent. Apart from its ready availability in most parts of the country, and its cheapness, it has a couple of physical properties which work to the firefighter's advantage.

When any cold substance comes into contact with a hot one, heat is conducted from the hotter to the cooler. The important difference with cold water is that it gets changed from a liquid into a gas (steam) at 100°C. The amount of energy necessary to do this (the latent heat of vaporisation) is far higher than is necessary to heat water

up to its boiling point. This energy has to come from somewhere. When water is turned into steam, large amounts of energy are absorbed from the hot gases and fuel in the fire, greatly cooling them.

When water is turned from a liquid into a gas, another very important physical effect occurs - it expands rapidly. If this were to happen in a sealed compartment this would cause a dangerous rise in pressure, but in a typical fire compartment, it causes a general outward flow of gases, driving the hot gases out of the compartment and preventing fresh air from reaching the fire. This can pose a hazard to firefighters due to the risk of burns from the hot gases and scalds from the steam.

These physical properties of water can be used to produce a wide variety of effects in a compartment fire. In some circumstances the application of water can have a detrimental effect on fire fighting but, properly applied:

- * water directly cools the fuel to reduce further generation of flammable gases;
- * water is converted into steam in the plume and the hot gases at ceiling level, absorbing heat, so cooling them and reducing the radiation heating the fuel;
- * once converted into steam, water limits the amount of oxygen reaching the flames, smothering them;
- * once converted into steam, water expands rapidly driving the products of combustion out of the compartment; and
- * water cools the rest of the compartment, increasing the amount of heat it will absorb from the plume, so cooling it further.

4 The Effect of Walls and the Ceiling on the Plume

Combustion in the plume requires the presence of oxygen and the updraught from the plume draws air in towards it. If the fire is in the centre of the compartment, air will be drawn from all directions, although most will come from the direction of the primary air supply into the compartment.

If the fire is at a wall, the plume may attach itself to it. As air entrainment will only occur on one half of the plume, that half directly opposite the wall, it will take longer for the flammable gases to burn and the flame height will increase.

If the fire is in a corner, air entrainment can only occur over a quarter of the plume, so the flame will rise higher still. If the walls consist of flammable materials, and the plume contacts them, they will quickly become involved, further increasing the flame height.

When the plume reaches the ceiling, it will spread out, moving across the ceiling until it finds a way out. If it can't at first find a way out, the products of combustion will build up at ceiling level forming a smoke layer with, sometimes, a clearly defined boundary between it and clear air. This boundary closely matches the division

between the cool gases at low level in the compartment, and the hot gases at ceiling level, which can be at a temperature of many hundreds of degrees Centigrade.

This boundary will descend as the fire grows. Once the products of combustion have found a way out, and the smoke supply from the plume matches the rate at which the smoke can leave the compartment, a degree of stability will result for a short while. The smoke boundary will stay roughly at the same height. This boundary could be lower than half the height of the compartment, depending on the layout of windows and doors, and the relative sizes of the compartment and the fire.

5 Actions by Firefighters

Firefighters should keep low in fires, to stay below this boundary. It must be remembered that the insulation in firefighters' clothing only serves to delay the time when they start to become uncomfortably hot and have to withdraw. If firefighters are to remain capable of working for any length of time inside a building on fire, they must avoid contact with hot gases whenever possible.

6 The Effect of Ventilation

The purpose of ventilation during a fire is to release the products of combustion from the compartment so as to prevent them causing further fire growth. Useful side effects of this are that, if the air-flows are properly managed, air temperatures will be reduced and visibility will be increased, making the firefighters' job easier. However, the firefighter should be aware that the increased air supply may cause the fire to intensify. This is discussed in more detail in the next section.

Ventilation is defined as:

"THE REMOVAL OF HEATED AIR, SMOKE, OR OTHER AIRBORNE CONTAMINANTS FROM A STRUCTURE AND THEIR REPLACEMENT WITH A SUPPLY OF FRESHER AIR".

The basic principles of ventilation are:

- * whenever possible, hot gases should be released from high in the compartment, and the replacement fresh air should be allowed to enter at low level. This takes full advantage of the buoyancy of the hot gases, and minimises mixing within the compartment. The two vents should be similar in size;
- * the high level vent should be down-wind of the low level vent, to take advantage of air flows induced by the wind;
- * if it can be achieved, roof ventilation will be most effective and should be carried out as close to the fire as safety permits;
- * the high level vent should be made before the low level vent;
- * if possible, the compartment should be vented from outside the building. Any backdraught would then be directed outwards, with less risk to firefighters. The

initial fire-ball might be spectacular, so the risk of igniting the building's eaves and surrounding risks would have to be considered, and charged branches made available to cover them; and

* the hot gases in the compartment can be cooled to reduce the potential for a backdraught, and the hot gases coming out of the vent can be cooled to prevent their ignition. Sprays and fogs have been found to be more effective than jets at this. However, water should not be directed in through the hot gas vent, as this may prevent the gases from escaping and drive fresh air in, inducing a backdraught.

Chapter 2 - Backdraughts

1 Reducing the Oxygen Supply to a Fire

In general, the hot gases generated in the plume will rise extremely rapidly and will draw air in towards the fire. If there is an adequate air supply, the fire will continue to burn and grow as long as there is fuel available.

If the air supply to the compartment is restricted, the oxygen in the air inside may be used up more quickly than it can be replaced. The net effect will be a progressive lowering of the concentration of oxygen in the gases in the compartment possibly combined with an increase in the temperature in the compartment.

As the oxygen concentration in the compartment reduces, the flames will start to die down, but this will not immediately result in a reduction in the production of flammable gases. Although the radiated heat from the plume reduces, the compartment is still very hot, and nothing has happened to cool the fuel. There may still be flames present, or they may die out altogether. Depending on the relative sizes of the fire and the compartment at this stage, sufficient flammable gases may be generated to spread throughout the compartment. This requires only a new supply of oxygen caused for example by opening a door, for it to form an explosive mixture with potentially lethal consequences - a BACKDRAUGHT.

2 The Definition of a Backdraught

Limited ventilation can lead to a fire in a compartment producing fire gases containing significant proportions of partial combustion products and unburnt pyrolysis products. If these accumulate then the admission of air when an opening is made to the compartment can lead to a sudden deflagration. This deflagration moving through the compartment and out of the opening is a backdraught.

3 Possible Backdraught Scenarios

There are two different backdraught scenarios, any one of which could be awaiting the firefighter.

* If the fire is still burning in the compartment when the firefighter opens the door, and especially if the combustion gases are not escaping, the air which enters through the door may mix with the flammable gases, forming an explosive mixture.

If the gases in the compartment are hot enough, they will then ignite on their own (auto-ignite) at the doorway, and the flame will spread back into the compartment along with the fresh air supply. This would result in rapid fire growth, but not necessarily in a backdraught.

If the compartment gases are not that hot, they will be ignited when sufficient oxygen has reached the gases surrounding the fire. Flame will then travel across the compartment towards the door, resulting in flame shooting out of the door

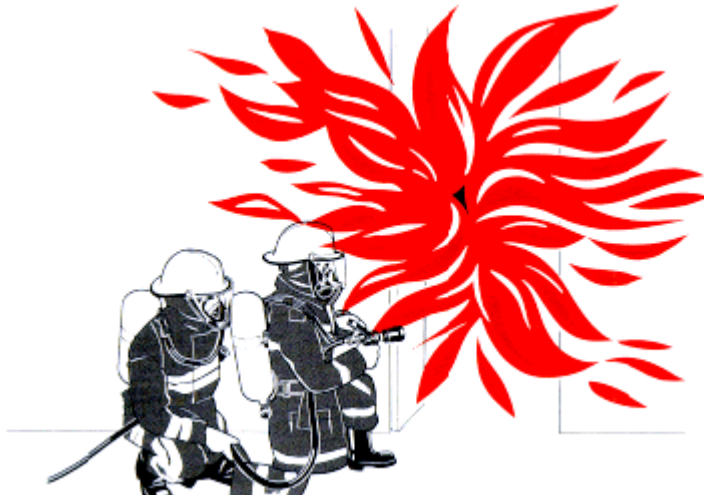

(Figure 2.1) , driven by the expanding gases behind it. It is not easy to predict whether this will actually happen, or how long it will take, once the door has been opened. This will depend on where the fire is in the compartment, the rate at which air flows in through the door, and whether the hot gases can escape without mixing with the incoming air.

* A more dangerous situation can occur when the fire in the compartment has almost died out. When the door is opened, the air flows in and an explosive mixture may be generated, but nothing happens because there is now no immediate source of ignition. If the firefighters now enter the compartment, their activities - for example, turning over may expose a source of ignition, initiating a delayed backdraught but now with them inside the compartment and surrounded in flame



(Figure 2.2) .

This can still occur even when the fire is apparently out and the compartment has cooled down. Foam rubber, in particular, can smoulder for a long time, producing flammable gases. Whenever, flammable gases remain in the compartment, they can be ignited. Cold smoke explosions occur in this way.

The situation can be further complicated if significant amounts of the flammable gases in the compartment have managed to escape into surrounding areas. Areas other than the closed compartment could then contain explosive atmospheres, waiting for a source of ignition. Most at risk is the area directly outside the compartment



(Figure 2.3) , exactly where the firefighters are waiting when they open the door. When the door is opened, flammable gases outside the compartment may be ignited by a backdraft within the compartment, by embers flying through the open door, or by the hot gases if they are at their auto-ignition temperature. It is even possible, though unlikely, for other areas of the building to be involved in a backdraught, ignited without there being a backdraught in the original compartment. Flammable gases outside the compartment may be ignited by embers flying through the open door, or if the hot gases in the doorway auto-ignite.

4 Signs and Symptoms of a Backdraught

The first clue to the possibility of a backdraught is the history of the fire: if the fire has been burning for some time, has generated lots of smoke which is now leaking out from the building, and has apparently died down without major areas of flame being visible from outside, the possibility is that it has died down from oxygen starvation.

When the building is viewed from outside, it is likely that the windows of the compartment concerned will be blackened with no obvious flames within. If part of a window is broken, it is possible that this will not provide sufficient oxygen to feed the fire. In this case it is likely that smoke will be pulsing out of the hole. Fresh air is drawn in as the fire cools slightly and the hot gases contract. This produces a local explosive mixture which burns, resulting in a mini-backdraught. The expansion of the hot gases in turn drives some smoke out of the compartment.

This cycle repeats itself at a frequency which depends on the size of the hole and the location of the fire relative to it.

If there is a gap under the compartment door, there may be smoke pulsing there due to the mini-backdraught effect already described. There may be a whistling noise if air is being drawn into the compartment through very small gaps around the door, but this could be difficult to hear. The door may be hot on the outside. In particular, the door handle may be hot if there is a metal rod linking it to the door handle on the other side.

If the compartment has been left long enough for it to cool down, air will no longer be drawn in, and the smoke pulsing effect will not be evident. However, if the compartment has not been ventilated and there are still flammable gases present, a backdraught is still possible.

If the decision is taken to open the door, there may be an in-rush of air as soon as the door is ajar, showing either that there is a shortage of oxygen in the compartment, or that the compartment has been much hotter and is starting to cool. Small flames may appear where the gases from the room are meeting the relatively fresh air outside, indicating that there are flammable gases in the room which are sufficiently hot to ignite given a source of fresh air, even without any other source of ignition. In either case, it may still be possible to close the door before sufficient air has entered the compartment to trigger any possible backdraught.

5 Actions by Firefighters

Once the door has been opened on to a compartment with an oxygen starved fire and fresh air has been allowed in, there is little which can be done to prevent a backdraught happening. It is far better to make appropriate decisions before the door is ever opened.

When firefighters are faced with a closed door, and do not know what is behind it, they should check for any of the signs and symptoms described above before opening it, covering the door with a charged branch, should they decide to open it. If there is a build-up of smoke outside the compartment, the possibility of backdraught can be reduced by spraying these gases before the compartment door is opened. The firefighters should be ready to close the door quickly, if a backdraught appears likely. This may not prevent the backdraught but may direct its force away from the firefighters.

If firefighters believe that opening a compartment door may lead to a backdraught, opening that door must be as a result of a deliberate decision. As long as the compartment door is closed, firefighters have time to think about their actions. Once the door is open, they will only have time to react to events as they occur. Whilst the decision about the timing of opening the door can only rest with the firefighters who form the fire fighting crew at the scene, the consequences of that decision ultimately lie with the Officer-in-Charge of the incident.

However, the compartment will still have to be inspected at some stage. The priority is then to make it safe for the firefighters to enter. As already described, a backdraught can only occur when fresh air is permitted to enter the compartment. It is possible for firefighters to operate in a flammable atmosphere provided there is no opportunity for things to change and for fresh air to enter whilst the firefighters are

inside. It is difficult to be sure - a window might shatter, someone might unwittingly open another door to the compartment. The far safer solution is to remove the flammable gases from the compartment - ventilation.

It is important to recognise that ventilation requires that fresh air should be let into the compartment. Thus, there is the possibility that a back-draught may occur during ventilation, so appropriate precautions should be taken.

If it is decided that a compartment needs to be ventilated and once the method of ventilation has been selected by the Officer-in-Charge of the incident:

- * branches must be charged and in position prior to any ventilation being carried out;
- * firefighters must get down low, and well clear of the likely flame path back through the vent opening, should a back-draught occur; and
- * it must be remembered that a backdraught could be delayed several minutes and that it might have sufficient energy to break other windows in the compartment.

No compartment can be considered safe from a backdraught until it has been opened to fresh air for some time. However, once the compartment has been properly ventilated, fire fighters can tackle the fire knowing that there is no longer any possibility of backdraught.

Aide Mémoire 1

Backdraught

INDICATORS

- * Dense smoke with no obvious sign of flame.
- * Smoke blackened windows.
- * Smoke pulsing from doors and windows.
- * Signs of heat around the door.

SAFETY

- * Ensure you are properly protected.
- * Keep door closed and cover with charged branch.
- * If possible, keep out of the room and ventilate from outside.
- * Check escape routes are secure and, if necessary, protected.
- * Cool and ventilate the outer compartment.

- * Plan an escape route for the gases before releasing them.
- * Stay low and to the side of the door.
- * Open the door slightly and spray through, directing the spray upwards.
- * Cool as much of the compartment as possible.
- * Keep out of the way of the steam and hot gases.
- * Only enter the room if you have to - there may still be flammable gases present.

Backdraught created using the Fire Experimental Unit Simulator

A sequence of photographs from a backdraught simulator filmed at the Home Office's Fire Experimental Unit Simulation laboratory at Moreton-in-Marsh.

A methane flame has been burning in the compartment for some time, heating the ceiling and consuming the oxygen. The flame has gone out due to a shortage of oxygen, but the methane supply has continued, as though fuel in the compartment were still pyrolysing. The door at the left hand end of the compartment is opened after 6 min 0 secs, and an ignition source is turned on at the right hand end 5 seconds later.

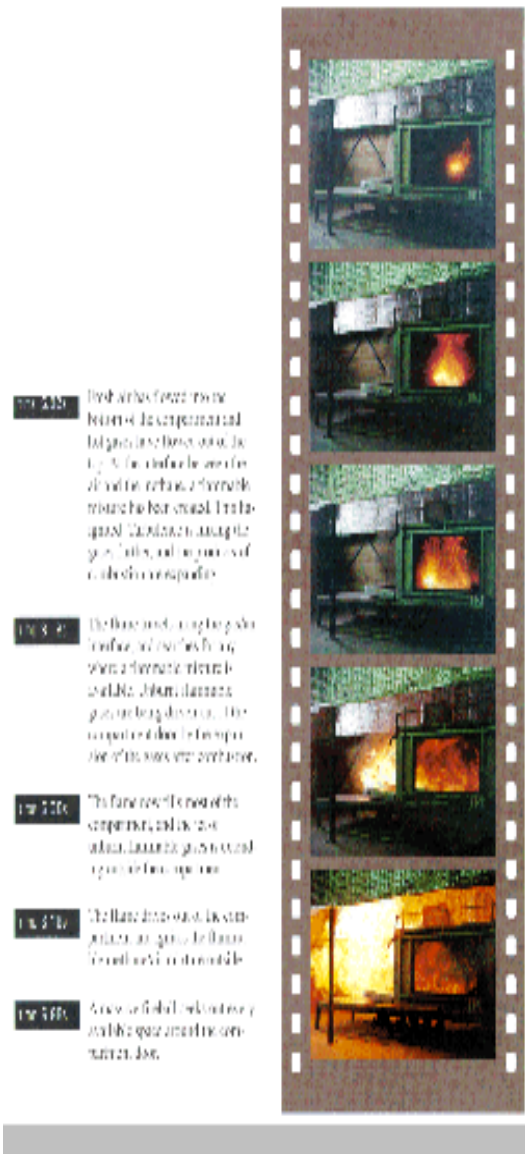

Chapter 3 - Flashovers

1 Fire Spread

It has already been described in Chapter 1 Section 4 how a smoke layer will build up when smoke cannot escape from a compartment as quickly as it is generated



(Figure 3.1) . However, if there is unburnt fuel in the compartment, things will not stay stable for long. Initially, the flame in the plume will not reach the ceiling and fire

spread will be limited to flammable materials close to the seat of the fire, ignited by radiated heat from the plume.

The flame height will increase until it reaches the ceiling. The flame will now start to spread across the compartment in the hot gas layer



(Figure 3.2) , with the flame appearing both at ceiling level above the plume, where air has been entrained, and at the boundary between the hot gas layer and clear air, as this is where the flammable gas in the ceiling layer can react with the oxygen.

Once flame has started to spread across the compartment at the boundary level, this will greatly increase the thermal radiation from the hot products of combustion already built up there. The other flammable materials in the compartment will now start to rise in temperature very rapidly. Not only are they being heated from the side by the plume, they are also being heated from above, where the flames and the hot products of combustion could be much closer, depending on the height of the boundary.

In large compartments with higher ceilings, flame and the hot products of combustion may spread at ceiling level without getting low enough to cause nearby fuel sources to start giving off flammable gases.

However, it may be that, at some distance from the fire, either a discontinuity in the ceiling causes the hot gases to swirl lower, or there is a high pile of flammable material. In either of these cases, the source of thermal radiation has been brought closer to the fuel, and ignition may result. By this mechanism, fire spread can cut firefighters off from their means of escape.

As the hot smoke layer descends, and particularly if there is a low ceiling, all the remaining contents in the compartment will now be heated to the stage when they will themselves start to give off flammable gases



(Figure 3.3) . It is then only a matter of time before there is a sudden change in the size of the fire, if no action is taken to prevent it. The smaller the compartment, the sooner these conditions are likely to be encountered.

Once flammable gases are being given off by the majority of the compartment contents, the transition from a localised fire to total involvement can take a matter of seconds - a FLASHOVER.

2 Definition of a Flashover

In a compartment fire there can come a stage where the total thermal radiation from the fire plume, hot gases and hot compartment boundaries causes the generation of flammable products of pyrolysis from all exposed combustible surfaces within the compartment. Given a source of ignition, this will result in the sudden and sustained transition of a growing fire to a fully developed fire. This is called flashover.

It can be seen that, according to this definition, a backdraught can be a special case of a flashover. If the backdraught results in a SUSTAINED fully developed fire, a flashover has occurred. Nevertheless, it is important to be able to draw a distinction between the two because the implications for firefighters are very different.

3 Signs and Symptoms of a Flashover

The primary requirement for a flashover to occur is that there should be significant thermal radiation from above. This will be felt by the firefighters as a rapid increase in the temperature in the compartment, and in the heat from the hot gases at ceiling level, forcing them down low. If they can see above them, they will be able to see tongues of flame running through the gas layer. In addition, other combustible materials within the compartment will be giving off visible smoke, and flammable gases.

4 Actions by Firefighters

As the main reason for a flashover is radiation from the hot gases and flames above them, the logical solution is to cool this area. This will have the effect of reducing the flames and radiated heat, and causing the smoke layer to lift. Directing a spray at the ceiling will have this effect. However, too much water will cause the generation of large amounts of steam. Too much cooling will bring the smoke layer down, obscuring everything.

In these circumstances, it will be most effective for the firefighters to attack the hot gases with pulses of spray, observing their effect, and so judging when sufficient water has been applied.

Once the immediate danger of a flashover has been eliminated, the next steps depend on whether flashover conditions could re-develop before the fire can be extinguished. If this is likely, it is important to ventilate the fire as soon as possible.

If the hot gases are released faster than they are generated, the smoke layer will reduce, and the risk of flashover will reduce. Built-in roof vents are designed to do exactly this, either automatically, or when operated by the fire service. However, it is

important that the correct vents are opened. The further from the fire that the vent is, the further the hot gases have to travel, and the more the chance of fire spread.

Where there are no built-in vents, firefighters have the option of making their own. It must be remembered, however, that incorrect use of ventilation can result in increased fire-spread at high level as hot gases are channelled into areas they might otherwise have taken longer to reach.

Aide Mémoire 2

Flashover

INDICATORS

- * A rapid increase in compartment temperature and in heat from hot gases at ceiling level.
- * Tongues of flame visible in the smoke layer.
- * Other surfaces giving off fumes.

SAFETY

- * Make sure you are properly protected.
- * Ensure entrance covered by a charged branch.
- * Check escape routes are protected.
- * Check the outside of the door for signs of heat.
- * Stay low.
- * Use spray pulses on hot gases at ceiling level.
- * Ventilate only when safe to do so.
- * Be aware of the potential for flashover and backdraught.

Build up to Flashover

A sequence of photographs from an enclosed room-fire filmed at the Home Office's Fire Experimental Unit Still-Air laboratory at Little Rissington.

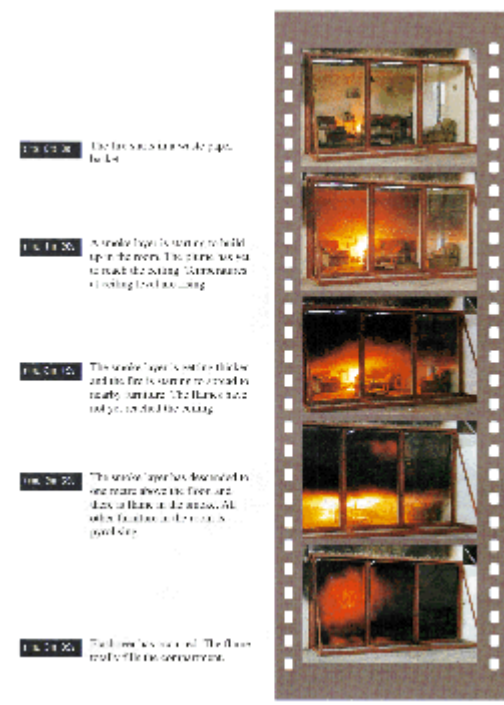

Chapter 4 - Firefighter Awareness

Officers have the important responsibility of deciding whether to commit breathing apparatus teams inside a building. It is essential that they are aware of the potential for backdraughts and, where their occurrence is more likely, the outside of the building should be checked for indications of a possible backdraught, and appropriate warnings must be given to the crews before they are committed.

It is essential that, from the moment firefighters enter a building, they are constantly aware of the possibilities of backdraught and flashover, and that they stop, look and think before they open any door inside a building.

Bibliography

Drysdale, D. 1985 An Introduction to Fire Dynamics, John Wiley and Sons

Wharry, D. 1974 Fire Technology - Chemistry and Combustion, The Institution of Fire Engineers

Part 2 Tactical Ventilation

Chapter 1 - Introduction

1 Ventilation

Ventilation is defined as:

"THE REMOVAL OF HEATED AIR, SMOKE AND OTHER AIRBORNE CONTAMINANTS FROM A STRUCTURE, AND THEIR REPLACEMENT WITH A SUPPLY OF FRESHER AIR".

In firefighting, there are a number of additional terms which are used:

SELF VENTILATION occurs when the fire damages the structure so that increased ventilation occurs.

AUTOMATIC VENTILATION occurs when pre-installed vents are activated automatically, usually in the early stages of the fire, by the fire detection system or fusible link devices.

TACTICAL VENTILATION requires the intervention of the fire service to open up the building, releasing the products of combustion and allowing fresher air to enter.

This manual is concerned with tactical ventilation, although many of the effects which will be described, will also occur during the other types of ventilation.

Tactical ventilation can only occur once the fire service attends a fire, and so usually occurs later than automatic ventilation. It can be used at various stages of a fire:

- * after arrival of the fire service but before control is achieved:
- * after control but before fire extinction:
- * after fire extinction.

When tactical ventilation is used before extinction, it can have an effect on fire spread. This can be either beneficial or detrimental, depending on the judgement and skill of the firefighters.

2 Smoke

Smoke is generally a mixture of fine solid particles, droplets of water and other liquids, and gases given off by the materials involved in the fire. It is generally toxic. The amount of smoke generated by a fire is dependent on the size of the fire and the material being burnt. Its behaviour and movement depends upon its temperature. The fire will heat the air and smoke surrounding it and, since hot air is more buoyant than cold air, it will tend to rise very rapidly and with great force. When the hot smoke and air cools this effect will cease and the smoke will tend to form layers. Movement of the smoke will then be more influenced by air turbulence caused by the making of openings into the compartment, the movement of people and the use of branches etc, than the temperature.

It is essential to remember two important features of smoke:

- * It can burn. Some of the products of combustion may not be fully burnt because of a shortage of oxygen or the absence of a source of ignition. Given a new source of fresh air, and a source of ignition, it can re-ignite, sometimes with explosive results --

a backdraught. If the smoke is hot enough, re-ignition can occur without a separate source of ignition.

* It can be hot. It may be sufficiently hot to ignite flammable materials with which it comes into contact. It will also be radiating heat, and this may be sufficient to ignite other sources of fuel in a compartment.

Two of the phenomena which can be caused by smoke, 'Flashover' and 'Backdraught', are described in the Part 1: Compartment Fires. Tactical ventilation is one of the techniques which can be used to prevent flashover and backdraught, or to mitigate their effects.

3 The Value of Ventilation

Like any other tactical option available to the firefighter, tactical ventilation can make things worse if it is applied incorrectly. Properly used, it can have significant beneficial effects on fire fighting:

- * it can assist escape by restricting the spread of smoke, improving visibility and extending available egress times;
- * it can aid rescue operations by reducing smoke and toxic gases, which hinder search activities and endanger trapped occupants;
- * it can improve the safety of firefighters by reducing the risk of flashover and backdraught, and making it easier to control the effects of backdraught;
- * it can speed attack and extinguishment by removing heat and smoke so that firefighters can enter a compartment earlier and, with improved visibility, make it easier for firefighters to locate and deal with the fire;
- * it can reduce property damage by making it possible for the fire to be located and tackled more quickly;
- * it can restrict fire spread by limiting the movement of smoke and hot gases.

4 When to Use Ventilation

Like any other technique available to the firefighter, tactical ventilation needs to be borne in mind when assessing how to tackle a fire.

In the majority of instances, tactical ventilation should not be used until the fire has been located and, in all cases, an assessment must be made of the likely effects of ventilation.

Often the fire's location can be determined from outside the building. On occasions, tactical ventilation can be used to clear smoke to help locate the fire.

In most cases, where ventilation is considered a suitable tactic, it is most effective if used in the early stages of firefighting. However, the uncontrolled movement of hot

gases inside the building is the main cause of fire spread, so the decision to commence tactical ventilation must be as part of an overall strategy of controlling air movements within the building.

5 The Effect of Wind

Wind strength and direction are usually the dominating factors in tactical ventilation. In most cases, it will determine the direction in which the smoke and hot gases will move within the building.

It is unlikely to be possible to fight against the prevailing wind by using fans to force air into the building. The efficiency of this tactic will depend on the capacity of the fans, when compared with the wind strength. If the wind is too strong, it will still dominate.

6 Tactical Ventilation Techniques

All ventilation techniques depend on planning where fresh air will be allowed to enter the building, where hot gases and smoke will be allowed to leave the building and, if possible, the routes they will follow within the building.

There are two basic options:

* VERTICAL OR TOP VENTILATION - making an opening at high level (usually through the roof) so that the buoyancy of the hot gases and smoke enables them to escape vertically

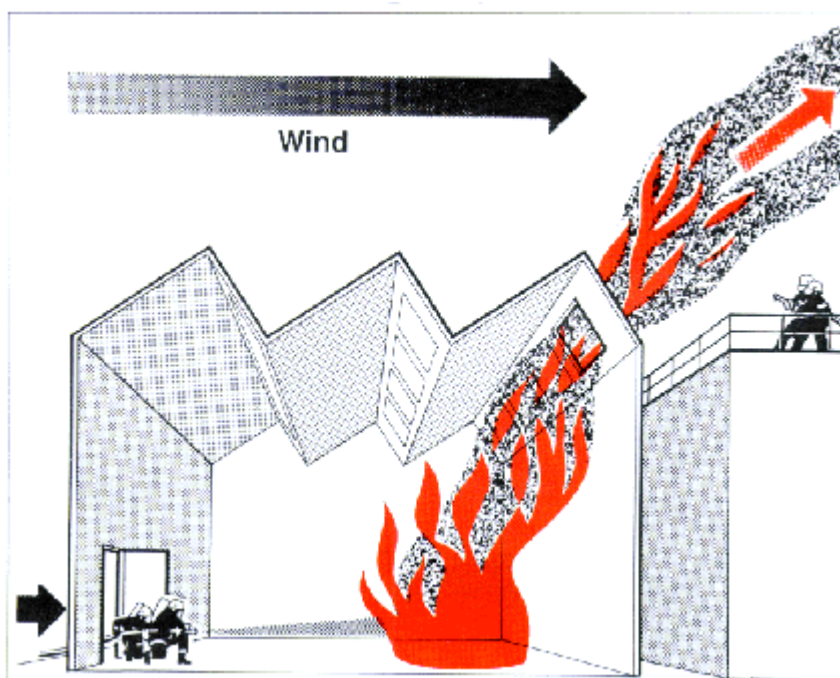

(See Figure 1.1) .

* HORIZONTAL OR CROSS VENTILATION - making openings in the external walls (for example using windows and doors) so that the wind assists in the removal of the hot gases and smoke

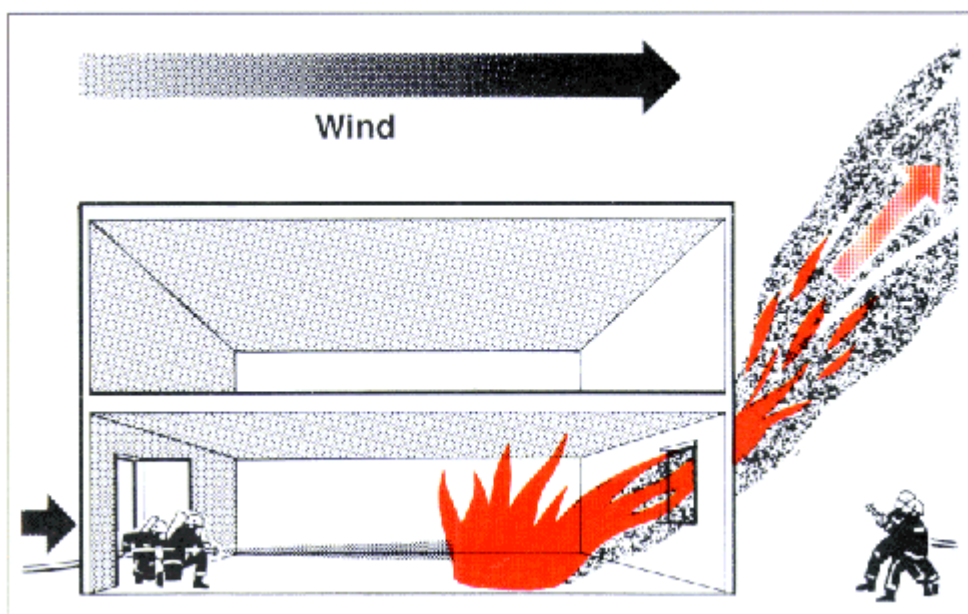

(See Figure 1.2) .

In both cases, it is possible to accelerate ventilation by the use of fans or blowers. In this manual, two terms are used:

* NATURAL VENTILATION describes collectively the techniques of vertical and horizontal ventilation when they are not assisted by mechanical means. This includes the use of pre-installed vents, windows, doors etc.

* FORCED VENTILATION describes collectively the techniques of vertical and horizontal ventilation when mechanical means are used to assist in removing the hot gases and smoke, or in providing a supply of fresh air. It includes the use of both fans and water sprays when used to drive the flow of fire gases or of fresh air.

7 Operational Command

Ventilation can only be one element of the overall firefighting strategy. It must be coordinated with other activities to ensure that differing requirements do not come into conflict. The decision to use forced ventilation will have further implications both for safety and for resources.

Sound tactical decisions, taken by officers responsible for the management of an incident, AND EFFECTIVE FIREGROUND COMMUNICATIONS, are essential for the safe use of ventilation.

Any firefighters inside the building need to be able to inform the Officer-in-Charge of the conditions within the building, and are likely to be in the best position to advise on whether tactical ventilation is likely to be effective. In particular, they may be best

placed to assess whether there are compartments where there is a risk of a backdraught.

If the Officer-in-Charge decides that ventilation will be initiated, the firefighters inside must first be informed. The Officer-in-Charge may decide to evacuate the building whilst ventilation takes place and until conditions have stabilised. Particular care should be taken of the safety of firefighters on storeys above the fire when ventilation is initiated.

If it is decided that the firefighters shall remain within the building, they will need to be able to inform the Officer-in-Charge when they are ready for ventilation to commence, and to report on the progress of the ventilation. These firefighters need a hoseline to protect themselves.

Firefighters outside the building also need to have their activities co-ordinated. The firefighters making the outlet vent are likely to be out of sight of the inlet vent, but it is important that ventilation activities occur in the correct sequence.

Whilst the fire is being fought, vents should only be opened as part of the ventilation plan. Care should also be taken to ensure that key doors are not accidentally opened or closed during firefighting operations. Once the fire has been extinguished, ventilation can be increased.

Chapter 2 - Assessing the need for ventilation

1 General

When the Officer-in-Charge is deciding on the overall strategy at a fire, ventilation is one of the factors which should be born in mind from the outset. Some situations cannot justify its use, particularly where the hot gases and smoke are not a serious problem, although it may still be necessary to ventilate after the fire has been extinguished, in order to remove residual smoke from the structure.

One critical factor may be the presence of built-in ventilation systems. These may be specifically designed for fire ventilation, but even then it is important that they are used correctly. They may already have activated automatically, in which case any decision to reverse this by manual intervention with the system, is as critical as a decision to start ventilation.

Built-in air conditioning systems can be equally important. If they are still operating, they may be supplying fresh air to the fire, and may be drawing the hot products of combustion into hidden ducts and voids, thus increasing the likelihood of fire spread. Again, these systems can be used as part of tactical ventilation but only to provide a supply of fresh air, acting as an inlet vent. They should not be used to provide an outlet vent unless the Officer-in-Charge is certain that this will not lead to fire spread.

If it is decided that tactical ventilation is required, the objective of its use should be identified before commencing operations. The technique to be adopted will vary, depending on what is expected of it. In particular, the approach can be:

- OFFENSIVE - ventilating close to the fire to have a direct effect on the fire itself, to limit fire spread, and to make conditions safer for the firefighters

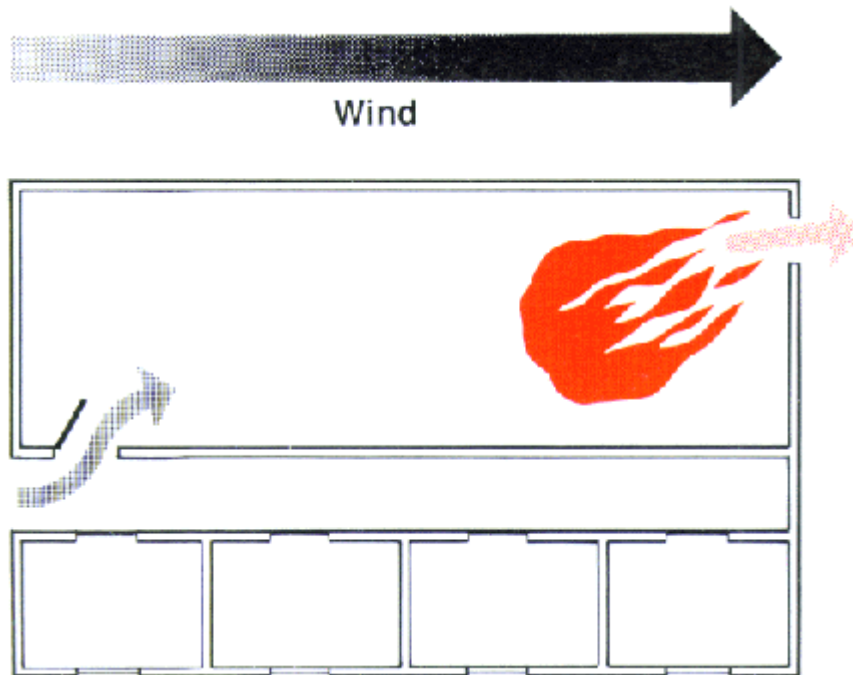

- (See Figure 2.1) ; or

* Defensive - ventilating away from the fire, or after the fire is out, to have an effect on the hot gases and smoke, particularly to improve access and escape routes and to control smoke movement to areas of the building not involved in the fire

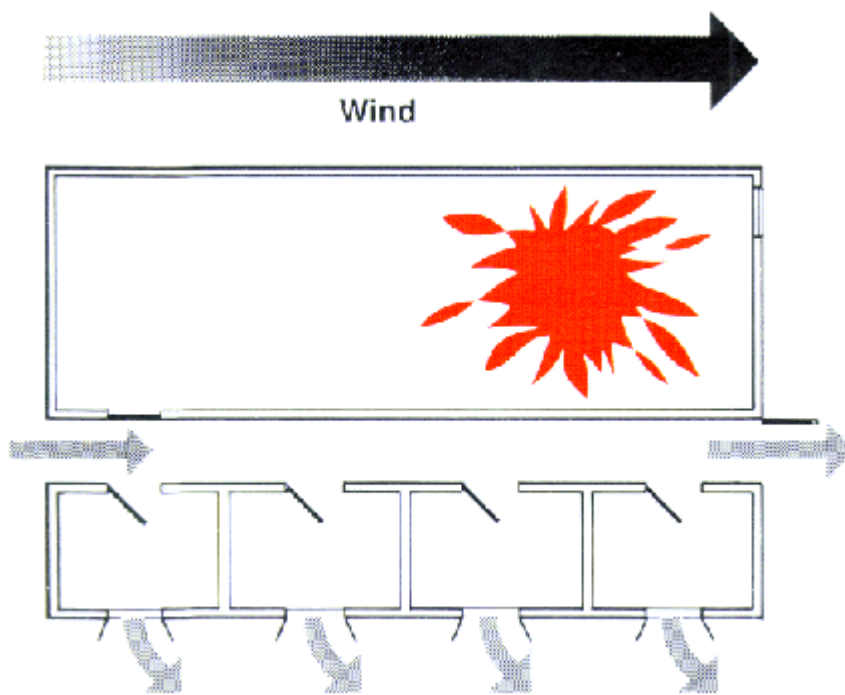

(See Figure 2.2) .

These two objectives can be met at the same time, for example to maintain a safe egress whilst offensive operations take place.

2 Where Ventilation May Be of Benefit

Ventilation can be useful whenever the removal of hot gases and smoke will make firefighting operations easier and safer.

If there is the risk of a backdraught, the compartment concerned has to be cleared of flammable gases in a controlled manner. If the compartment door is opened, that is the most likely route for the backdraught, endangering the firefighters in the vicinity of the open door. Properly applied, ventilation could release the gases externally, directing any flame or explosion away from firefighters and other fire risks

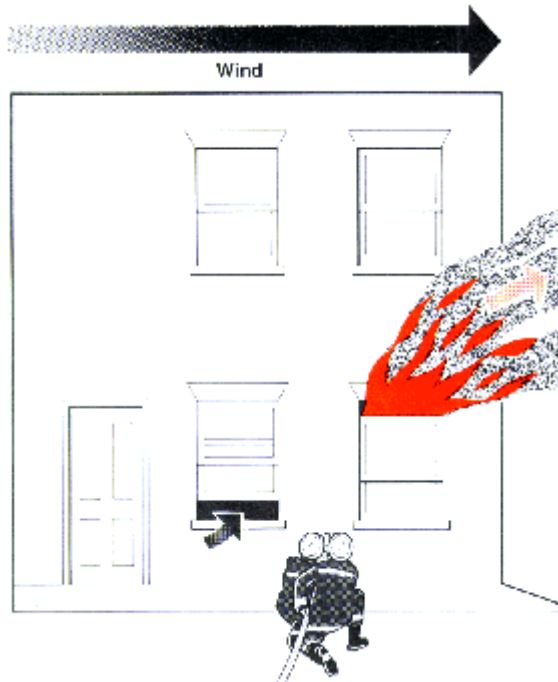

(See Figure 2.3) .

If there is a lot of hot gas and smoke in a compartment, with flame travelling horizontally at ceiling level, there is a significant risk of rapid fire spread and possibly flashover. These gases need to be ventilated as close to the fire as safety permits, and preferably at high level. If the only possible vent is some distance from the fire, it must be expected that fire will spread along the route to that vent once ventilation commences.

If the escape route from the building contains smoke, and there are still persons in the building, ventilation can clear that route

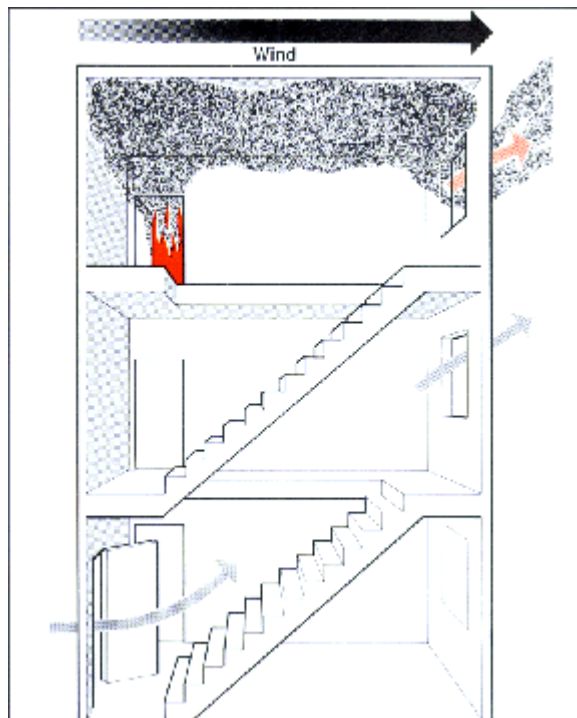

(See Figure 2.4) .

If firefighters are hampered in reaching the fire because the route they have to follow is smoke-logged, ventilation will help to improve visibility, speeding access. It may also be of benefit where, sprinklers have operated and cooled the smoke, causing smoke-logging.

If there has been a build up of hot gases within the building so that conditions for the firefighters are very arduous, ventilation can produce a much more tolerable environment, increasing a firefighter's working duration.

3 Assessing the Risks

The main risk in using offensive ventilation techniques is that the introduction of fresh air may result in fire growth and, perhaps, even backdraught. However, if a backdraught occurs, it is probable that the conditions necessary were already in being, and it would have occurred without the commencement of tactical ventilation.

Provided that sufficient fuel is present, fire growth may occur in the area surrounding the fire, and/or along the route to the outlet vent. Hot smoke and gases may also ignite as they are vented and meet fresh air. For this reason, it is preferable to vent the compartment directly to the outside.

The correct use of offensive ventilation can reduce the risk of fire spread by removing the hot gases whilst allowing fresh air in. However, offensive ventilation should never commence until appropriately protected firefighters are on hand with charged hoselines. This does not mean that the fire must necessarily be surrounded before ventilation commences. The initiation of offensive ventilation constitutes one of the elements in a major attack on the fire, but it cannot be treated as an attack in its own right.

The decision to ventilate offensively involves a balance between the risk of fire spread, and the improved conditions around the fire. The time and resources necessary to set up ventilation will also be factors which need to be considered.

Smoke-logging can occur in parts of the building not involved in the fire. This can cause hazards both to occupants trying to escape, and to fire-fighters involved in tasks away from the fire, and can result in severe damage to property. The correct use of ventilation can reduce this risk, whilst its incorrect use can make it far worse.

The Officer-in-Charge should consider the possibility of withdrawing the firefighters from part or all of the building whilst fresh air is being let into the compartment, particularly if the fresh air route is likely to become the path for any backdraught.

Where it is felt that defensive ventilation is more appropriate, the risks and benefits are proportionately less. It is, however, necessary to select an appropriate route for the air flow from the inlet vent to the outlet vent, to minimise the chances of this fresh air affecting the fire compartment.

Defensive ventilation does not have to form part of a major attack on a fire. It can be part of the build up to this attack, clearing escape and attack routes, or part of continuing operations once the fire is under control.

4 How Ventilation is to Be Achieved

This will always depend on the circumstances at the fire, but there are a number of guidelines to be followed. The principal decision is whether to use Horizontal Ventilation or Vertical Ventilation, and secondly whether to adopt an offensive or a defensive approach.

In both cases, the major factors to be considered are the design of the building, the location, size and severity of the fire, and the wind speed and direction.

Horizontal Ventilation may be appropriate where:

- * vertical ventilation is not possible due to the character of the building;
- * it is not safe to commit firefighters to open a vent in the roof;
- * the fire is not large enough to necessitate opening of the roof;
- * there are windows and doors close to the seat of the fire;
- * the fire and the products of combustion are not being carried into other floors;
- * the fire has not entered structural voids or concealed spaces.

Vertical ventilation may be appropriate where:

- * the fire is in, or has spread to, the roof space;

- * horizontal ventilation would be difficult, for example, in windowless buildings with few external doors;
- * there are tall vertical shafts, such as light wells or elevators;
- * the fire has entered structural voids or concealed spaces.

In general, the use of forced ventilation (e.g. fans etc.) will speed up whatever ventilation process is selected.

Horizontal Ventilation is most effective where the outlet vent can be placed high on the downwind side of the building, and the inlet vent is low on the upwind side. If the only suitable windows and doors are all on the same side of the building, the use of natural ventilation may not be very effective, as the pressure of the wind will act equally on the inlet and outlet vents.

In these circumstances, the cool air will enter at low level, and the hot gases will come out at high level. Forced ventilation may offer some improvement where it does not result in flame being driven at the firefighters.

Chapter 3 - Horizontal Ventilation

1 General

Horizontal ventilation is the most frequently used form of ventilation because, in the majority of situations, it is the most appropriate method with which to ventilate the building, and is often the easiest. Also, firefighters entering a building for search and rescue or fire attack start a form of horizontal ventilation by opening doors or windows to make entry.

Many fires in buildings do little damage by direct burning, yet produce fairly large volumes of smoke. These situations may only require that the windows and doors of the affected compartments be opened to allow the residual smoke to be ventilated.

In other situations, such as dealing with a severe fire below the top floor of a building, horizontal ventilation may also be beneficial.

This section describes the technique of horizontal ventilation, and the ways in which it can be achieved.

2 The Physical Principles Involved

Smoke movement is caused by two factors: the wind, and the temperature (and hence the buoyancy) of the gases.

The relative significance of these will depend on their magnitudes. Close to a fire, the buoyancy effects are likely to be dominant.

When the smoke and gases from a fire are hot, their buoyancy will increase and they will rise. If they are very hot, they will rise very rapidly. In some circumstances,

large volumes of air can then be entrained, greatly increasing the air and smoke flows involved.

Away from the fire, the wind effects are likely to be dominant.

3 The Principles of Horizontal Ventilation

Ventilation requires the CONTROLLED release of smoke and hot, possibly flammable, gases from a building, and their replacement by fresher air.

The operative word in this description is 'controlled'. Opening doors and windows at random can make matters worse, causing fire spread and increased smoke damage, and increasing the possibility of a backdraught.

The firefighter should first seek to release the products of combustion on the downwind side of the building, from as high in the compartment as possible.

Then, once the outlet vent has been opened, an inlet vent should be created on the upwind side of the building, and as low in the compartment as possible, to take advantage of the buoyancy of the smoke and hot gases.

For DEFENSIVE ventilation, the location of the vents is determined by the route between them. The overall objective is to let fresh air into as much of the building as possible. The building layout will determine the route the air takes, once the vents are opened. Their locations need to be chosen to avoid directing fresh air towards the site of the fire.

For OFFENSIVE ventilation, the outlet vent should be as close to the fire as practicable. It is desirable to use the firefighters' route to the fire as the inlet vent, as this reduces smoke and heat along their route, making their job safer and more tolerable.

In this case, the gases coming out of the vent are likely to be very hot, and possibly flammable. Flames are likely to appear outside the vent if the smoke and gases are above their auto-ignition temperature. There is a risk of fire spread.

Therefore, before the outlet vent is opened, its position must be covered by an appropriately protected firefighter with a charged branch. This branch can be used to cool the smoke and gases as they come out, but under no circumstances should the water be directed in through the vent, as long as ventilation is in progress. This will interfere with the ventilation process and could place fire-fighters inside the building at risk.

If the compartment containing the fire has become oxygen starved, there is the risk of a backdraught. Creating an outlet vent to this compartment may trigger a backdraught, but the risk of this is minimised if the vent is high in the compartment, and on the downwind side, allowing the release of hot gases without mixing them in the room with fresh air.

If all other exits from the compartment are closed, the force of any backdraught will be directed out of the vent. The firefighters making the vent should take appropriate precautions, such as keeping well clear of the path of any possible backdraught, wearing breathing apparatus, staying low and having a charged branch available for use.

The introduction of fresher air is the most likely trigger for a backdraught. Ventilation of an oxygen starved compartment is an inherently dangerous activity for those inside the building. Once the outlet vent has been made, the hot smoke and gases will be released, and the temperature in the compartment should reduce. However, the compartment can only have become oxygen starved because there is an inadequate supply of fresh air into it, so an inlet route for fresher air has to be established as soon as practicable, or the potential for a backdraught could remain.

The Officer-in-Charge should consider withdrawing the firefighters from part or all of the building whilst fresh air is being let into the compartment, if the fresh air route is likely to become the path for any backdraught. Particular consideration should be given to the safety of any firefighters on storeys above the fire - especially where their access and/or escape routes run through part of the fresh air inlet path (e.g. where the fresh air inlet path occupies part of a stairwell).

4 Methods of Making Vents

If inside, the simplest method of making a vent, doing the least damage, is to open a window or door. If possible, the top of a window should be opened to make an outlet vent, and the bottom of a window opened to make an inlet vent.

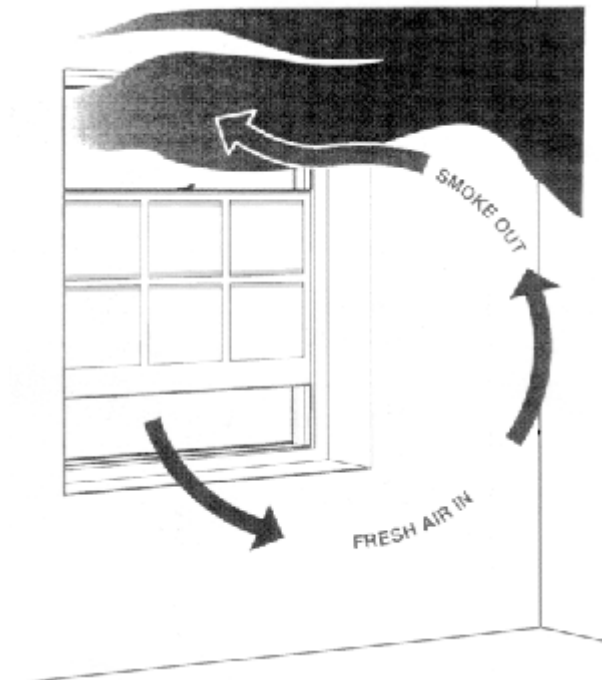

(See Figure 3.1)

It is preferable to open windows, rather than to break them, because they can then be closed again if necessary.

This should be done from outside whenever possible. In some circumstances, windows may have to be smashed

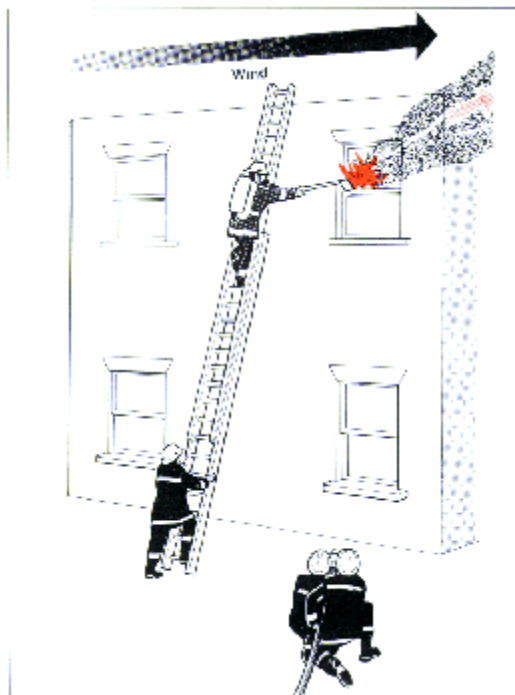

(See Figure 3.2) , but care has to be taken from three points of view:

- * the hot smoke coming out of the newly-made vent will rise, and may hug the surface of a wall or steeply-sloping roof above the vent. Firefighters opening a vent should never position themselves above the vent being cut.
- * letting fresh air into a compartment may result in a backdraught, so firefighters should not be directly in front of the window. They should be as far to the side of the window as is practical, reaching sideways, using an appropriate tool such as an axe or ceiling hook. If working from a ladder or aerial appliance, particular care needs to be taken to ensure that the head of the ladder is similarly sited.
- * the glass from a window can travel a long way outwards, particularly from higher storeys. This can kill or seriously injure fire-fighters or bystanders.

In some light-weight buildings, it may be possible to make a hole through the wall. Again, the firefighters should avoid being in line with the hole, in case of a backdraught.

Whilst the fire is being fought, vents should only be opened as part of the ventilation plan. Care should also be taken that key doors are not accidentally closed during firefighting operations. Once the fire has been extinguished, ventilation can be increased.

Chapter 4 - Vertical Ventilation

1 General

Vertical ventilation makes maximum use of the buoyancy of the hot smoke and gases, allowing them to escape harmlessly into the atmosphere by the most direct route possible. It is especially useful in potential backdraught situations.

The distinction between vertical and horizontal ventilation is in the location of the outlet vent. In horizontal ventilation, the outlet vent is placed as high in the compartment wall as possible. In vertical ventilation, the outlet vent is placed in the compartment roof, as close to the fire as is safely possible.

Vertical ventilation is most effective as an offensive ventilation tactic, used to affect the fire directly. In defensive ventilation operations, its efficiency depends on its proximity to the fire, and hence the buoyancy of the smoke and hot gases.

Thus, vertical ventilation is most applicable to buildings where the fire is directly below the roof. Where there is a ceiling or roof space which is not involved in the fire, vertical ventilation will result in fire spread into that space.

However, where the fire is already in the ceiling or roof space, there may be little alternative but to adopt vertical ventilation if it is safely practicable, although tiled roofs may leak enough for extra ventilation to be unnecessary.

The advantages of vertical ventilation are that:

- * it can minimise the risk of a backdraught. Initially the pressure in the compartment will drive the hot gases out. An inlet vent is then necessary or fresh air will start coming in through the outlet vent, mixing with the smoke to increase the likelihood of smoke-logging the compartment;
- * it can minimise fire spread, because the smoke and hot gases travel the shortest possible distance before leaving the building;
- * it can provide extremely rapid smoke clearance, because of the high velocity of the smoke and hot gases leaving through the roof vent. Large amounts of fresh air are drawn in to replace these.

The obvious disadvantage of vertical ventilation is that firefighting operations are required on the roof above the fire, and these can be extremely hazardous.

Nevertheless, it is possible to adopt working procedures which significantly reduce this risk, and these will be discussed later.

2 Vertical Ventilation Safety

The location of the fire has to be determined before vertical ventilation can be considered.

As standard practice, when vertical offensive ventilation is under way, the outlet vent must be covered by a charged hoseline, even whilst it is being made.

If safely practicable, any roof vent should be made with the firefighter working from a ladder

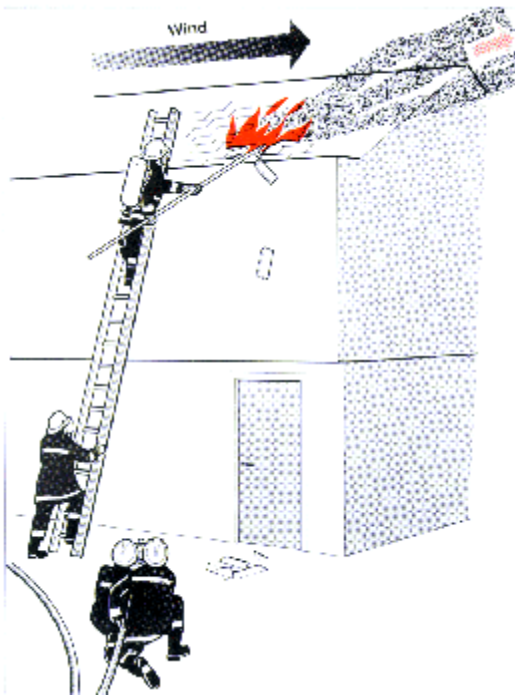

(See Figure 4.1) or from an aerial appliance, rather than from the roof itself. Even then, it must be remembered that, once the fire compartment has been penetrated, hot smoke and gases and possibly flames will come out of the vent, perhaps with some force. Breathing apparatus must always be worn in such circumstances.

If the Officer-in-Charge decides that a vent is required in the roof, and the location cannot be reached from a ladder or aerial appliance, serious consideration must be given to firefighters' safety, before committing them to a roof above a fire.

3 Methods of Making Vents

Some buildings have built-in mechanical ventilation systems operated from ground level. It may be possible to make use of these.

The next easiest way of making a roof vent is to take advantage of building features such as roof lights or dormer windows.

Where these do not exist, it may be possible to lift tiles and slates and to cut through whatever lies underneath.

Without a knowledge of the method of construction, it is not advisable to attempt to make holes in any type of roof.

The safest method of doing this is to work from a roof ladder or an aerial appliance.

Firefighters making a vent should avoid working from a location higher than the vent. For example, on a sloping roof, the firefighters should not be higher up the slope.

4 Offensive and Defensive Vertical Ventilation

Defensive vertical ventilation is possible but its efficiency will depend on its proximity to the fire.

If smoke clearance is the sole objective, this is likely to be taking place some distance from the fire, where the smoke and hot gases will have mixed with cooler air. They are unlikely to be hot enough to cause a rapid flow through the vent, and the whole process will be very slow.

It may be possible to speed this up if the inlet vent is on the upwind side of the building, but forced ventilation may be necessary.

Offensive vertical ventilation requires roof vents close to the fire. It is most effective if the vent can be placed directly above the fire.

Offensive ventilation can also be used to limit fire spread in large compartments, or linked roof spaces. In these circumstances, fire spread is caused principally by the hot smoke and gases spreading at ceiling level (Mushrooming) and either igniting structural members in the roof, or igniting more of the compartment contents by means of the heat radiating from the hot smoke layer.

The hot smoke and gases will spread inside the compartment until they can find a way out. Removing the roof covering in the form of a strip, ahead of the smoke spread, can limit this spread, effectively producing a fire break. This is known as trench or strip ventilation.

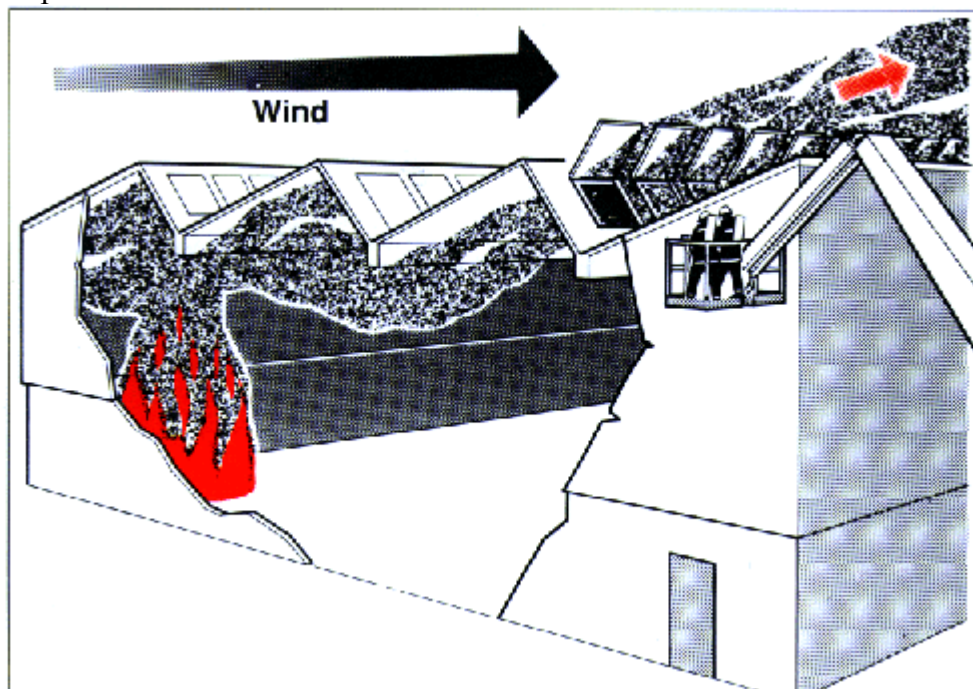

(See Figure 4.2)

Trench ventilation is accomplished by making an opening in the roof, at a safe distance from the fire, large enough for all the hot smoke and gases to vent through it, so that none go past the vent. This will cause fire spread in the direction of the vent,

but stop its movement past it. It will also cause any smoke layer within the compartment to lift.

In terrace-type properties, it may be necessary to make a trench cut to prevent fire spread to adjoining roof spaces.

It is safer to do this on the adjoining property. On a sloping roof, it is preferable to start cutting the trench at the highest point that can be safely reached, working downwards from that point, so minimising exposure to the hot smoke and gases.

Chapter 5 - Forced Ventilation

1 General

Ventilation efforts should be in concert with existing atmospheric conditions, taking advantage of natural ventilation whenever possible. However, in some situations, natural ventilation may be inadequate and may have to be supplemented or replaced by forced ventilation to provide a tenable atmosphere and to facilitate rescue operations.

Forced ventilation refers to the use of fans, blowers, water sprays or other mechanical devices to create or redirect the flow of air inside the building so that the fire gases are forced out of the building.

IF FORCED VENTILATION IS USED TO ACCELERATE THE EFFECTS OF NATURAL VENTILATION, IT MUST BE REMEMBERED THAT ALL THE EFFECTS, BOTH GOOD AND BAD, MAY BE ACCELERATED. For this reason, it is essential that the firefighters concerned have a good understanding of the principles of ventilation, and the behaviour of fire, before the use of forced ventilation is considered.

The main advantages of forced ventilation are:

- * the ventilation objectives, i.e. smoke removal, restoration of a tenable atmosphere etc., are achieved more rapidly;
- * it makes horizontal ventilation more effective, so reducing the need for vertical ventilation;
- * it is less susceptible to erratic wind conditions, although it cannot overcome strong winds;
- * it is a more controllable form of ventilation.

Its disadvantages are:

- * it requires the use of a mechanical device, a power source and additional firefighters;

- * it can increase the intensity of a fire and lead to unwanted fire and smoke spread if incorrectly applied;
- * to clear large compartments, it requires a very large fan, or a number of smaller fans;
- * it can take time to set up;
- * in defensive ventilation operations, the limited airflow available means that systematic room-by-room clearance is necessary.

The main techniques of forced ventilation are:

- * Positive Pressure Ventilation (PPV). PPV can be achieved by forcing air into a building using a fan. The effect of this will be to increase the pressure inside, relative to atmospheric pressure. PPV simply refers to blowing air in through the inlet vent.
- * Negative Pressure Ventilation (NPV). NPV refers to extracting the smoke and hot gases from the outlet vent. This will have the effect of reducing the pressure inside the building, relative to the atmospheric pressure. It can be achieved by fans or water sprays.
- * Heating Ventilation and Air Conditioning Systems (HVAC). Building HVAC systems can be designed so that, in the event of fire, they can be used as a smoke control system.
- * Powered Smoke and Heat Exhaust Systems. Dedicated fans and other devices which, usually triggered automatically, provide a smoke control system.

2 Positive Pressure Ventilation

The most appropriate tactic for using a PPV fan will depend on whether the inlet vent is also to be used for firefighters' access to the building and whether there is smoke coming out of that vent. If the vent is an entrance, the fan may cause an obstruction unless it can be placed a little way back, to allow access. However, this will reduce the efficiency of the fan

In some cases, it is important to prevent air from flowing out of the inlet. This would reduce the efficiency of the ventilation and, if there is smoke immediately inside the inlet vent, could result in turbulence in the smoke, increasing obscuration a short way inside the building.

This can be prevented in two ways:

- The fan can be placed in the doorway and the rest of the doorway blocked off. Clearly this will prevent the doorway being used for firefighters' access

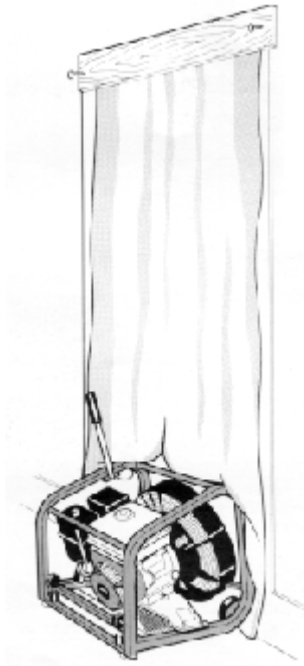

-
- (See Figure 5.1) .

* The fan can be moved back from the doorway until the cone of air it produces covers the whole of the doorway. This reduces the amount of air which is entering the building, but makes most efficient use of the air which does go in. It produces a moving wall of air which sweeps all the smoke and hot gases before it in the direction of the outlet vent

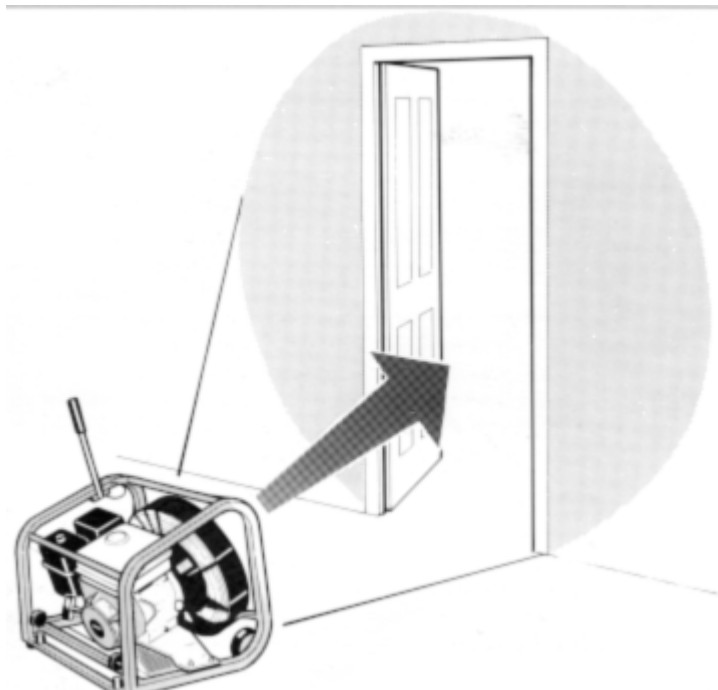

(See Figure 5.2) .

The efficiency of the smoke clearance is governed by the wind, the size and design of the fan, the proportion of the fan's air production which enters the building, the

relative sizes of the inlet and outlet vents, the size of the compartment to be cleared and the temperature of the gases in the compartment.

3 Negative Pressure Ventilation

(a) Fans

The most common method of achieving NPV is by the use of portable fans. These can vary widely in the amount of air which they can move, measured in cubic metres per minute. The more powerful the fan, the more air it can move.

The fans can be powered by electric motors, driven from appliance power supplies, or hydraulic motors, driven from the appliance pump. Diesel or petrol driven fans are inappropriate for use when surrounded by fire gases because they are unlikely to have a fresh air supply, necessary for their engines to work.

The main problem with the use of fans for NPV is that the fan components are unlikely to be designed to withstand high temperatures. If the smoke and gases being extracted are hot, the fans will soon cease to function.

The use of fans for NPV is better in the clearance of smoke-logged buildings once the fire is out, or where there is no prospect of hot or flammable gases reaching the fan.

(b) Hoseline Branches

It is possible to use the air entrainment effect of branches used on a conical spray setting, to draw air out of an outlet vent.

The conical spray should be directed out through the outlet vent from within the building. To protect the firefighter who would otherwise have to remain in a hot environment, the branch should be lashed in position or mounted on a branch holder, rather than hand held

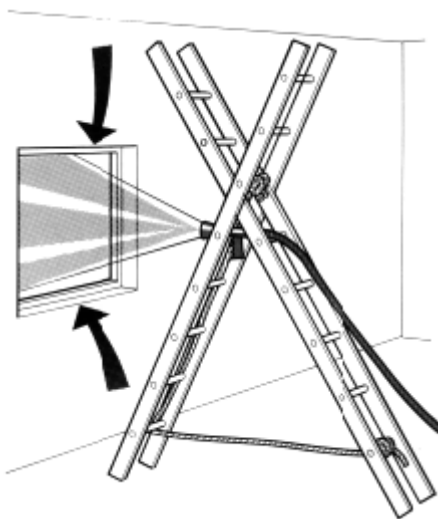

(See Figure 5.3) .

The spray should be set at a cone angle of about 60 degrees and located so that it covers 85-90 percent of the outlet vent surface area, to achieve the maximum air flow

This same effect can be used at the inlet vent, but water damage inside the building will be increased, and the firefighter holding the branch would have to be aware of the risk of backdraught in offensive ventilation operations.

This technique can be very effective in clearing smoke from a small compartment fire to enable early investigation of the scene and to reduce further damage.

4 Heating Ventilation and Air Conditioning Systems

Mechanical fire ventilation systems are described in the Manual of Firemanship, Book 9 Part 3. They usually work automatically, but there may be a manual over-ride. Where firefighters require the special operation of these systems, they should if possible consult the engineer responsible, as incorrect use could result in spreading the fire.

This also applies when firefighters have to face the fire hazards presented by the sort of ventilation system described in the Manual of Firemanship, Book 9, Chapter 20, 'Ventilation and Air Conditioning Systems', and on underground railways, where ventilation is effected by fans.

In some cases, air conditioning systems have been designed to act as fire ventilation systems in the event of fire. Where firefighters require the special operation of these systems, they should if possible consult the engineer responsible, as there may be limitations on the temperatures they can withstand, and their incorrect use could result in spreading the fire.

5 Powered Smoke and Heat Exhaust Ventilation Systems

Such systems are generally automatically triggered and are likely to be operating before firefighters arrive. These systems can be over-ridden manually, but this will need careful consideration by the Officer-in-Charge, as part of the firefighting and ventilation strategy.

6 Safety Considerations

The same safety considerations apply to the use of forced ventilation as apply to natural ventilation. The one difference is that everything will happen more quickly. Things can go wrong more quickly, just as ventilation can be achieved more quickly. Thus effective communication between all involved in firefighting operations is even more critical. The Officer-in-Charge must ensure that close supervision and monitoring is maintained throughout.

There is always the danger of driving smoke and/or flames into unstopped cavities, especially in traditional buildings. Flats and maisonettes, for example, frequently have inadequately stopped builders' ducts for pipes and cables. They shouldn't, but they do. Old, historic buildings are particularly notorious for hidden flow-paths for smoky gases. It follows that the use of PPV in particular should be monitored for smoke appearing in neighbouring compartments via unexpected routes. Where it occurs, there may be a case for using NPV.

The noise of the fans can itself pose a problem, affecting both those inside the building who may not be able to hear an emergency evacuation signal, and the Safety Officers who may not be able to hear a Distress Signal Unit if it is actuated. Briefing of firefighters may have to take place away from an operating fan.

Chapter 6 - Positive Pressure Ventilation (PPV)

1 Introduction

Positive Pressure Ventilation (PPV) is achieved by forcing air into a building using a fan. The effect of this will be to increase the pressure inside, relative to atmospheric pressure. PPV simply refers to blowing air in through the inlet vent. The most appropriate tactic for using a PPV fan will depend on whether the inlet vent is also to be used for firefighters' access to the building and whether there is smoke coming out of that vent.

It is essential to recognise that the use of PPV is simply an extension of the use of natural ventilation. The same fundamental principles apply to both. If PPV is used to accelerate the effects of natural ventilation, it must be remembered that all the effects, both good and bad, may be accelerated. For this reason, it is essential that firefighters have a good understanding of the behaviour of fire and the principles of ventilation, before the use of PPV is considered.

The efficiency of PPV as a tactic is governed by the wind, the size of the fan, the proportion of the fan's air production which enters the building, the relative sizes of the inlet and outlet vents, the size of the compartment to be cleared, and the temperature of the gases in the compartment.

2 Basic Fan Performance

It must be remembered that fans can differ widely in performance. To be considered portable, the fan should conform to the guidelines set out in the Manual Handling Regulations. The table below gives an indication of the power and weight of various fan designs, not all of which would be suitable for PPV.

The amount of air which a fan can move is a function of the power available and the design of the fan blade. The shape of the cone of air which is produced is a function of the design of the fan blade and of the ducting fitted around the fan.

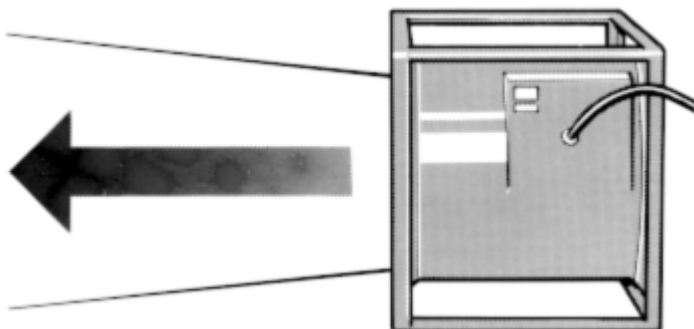

Figures 6.1 and

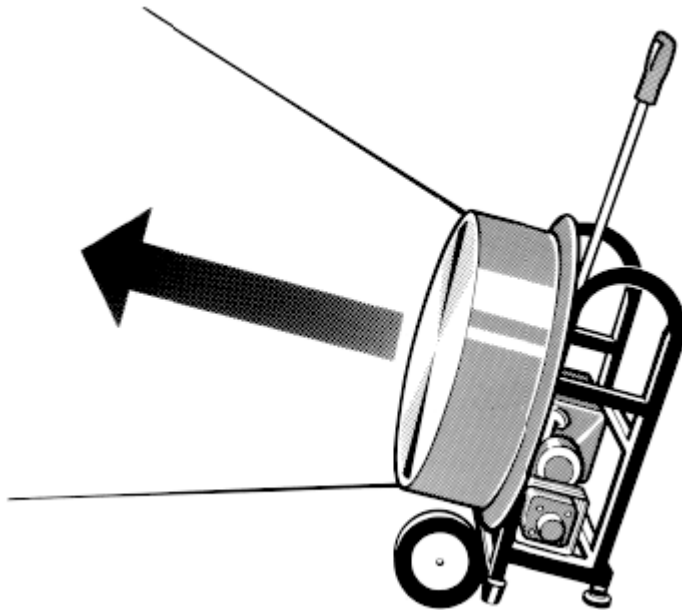

6.2 Figure 6.2 illustrate this.

When a fan is first used to pressurise a compartment, the time taken to do this is governed by the size of the compartment. A small compartment will be pressurised in seconds. The bigger the compartment, the more air which has to be driven into it to achieve the same level of pressurisation.

Table 1 - Power, Weight and Flow of 24" diameter PPV Fans with different power sources.

Power Source	Engine Power (kW)	Weight (Kg)	Flow cu m/sec	<i>Tab and PP pov</i>
Petrol	3.7/6.7	35/57	4.2/7.1	
240/110v Electric	0.7	32	3.5	
Water at 20 bar, 110 l/min	0.0-6.0	16	0-5.7	

If a typical PPV fan is placed in a doorway being used as an inlet vent, and no air is allowed to escape back out of that doorway, the flow rate of the fan will slowly reduce as the pressure in the compartment rises. The flow rate which can be achieved once things start to stabilise will depend on the size of the outlet vent.

* If the outlet vent is very large, compared with the inlet vent, the maximum flow rate which can be generated by the fan might be typically 6 cubic metres per second (210

cubic feet per second). The pressure rise inside the compartment would be very small.

* If the outlet vent is the same size as the inlet vent, the maximum flow rate reduces to typically 4 cubic metres per second (140 cubic feet per second), but the internal pressure may rise to typically 15 Pascals (0.15 millibar).

* If the outlet vent is half the size of the inlet vent, the maximum flow rate is typically 3 cubic metres per second (100 cubic feet per second), but the internal pressure rises to typically 30 Pascals (0.3 millibar).

Thus the relative sizes of the inlet and outlet vents can be used to trade off air flow against internal pressure.

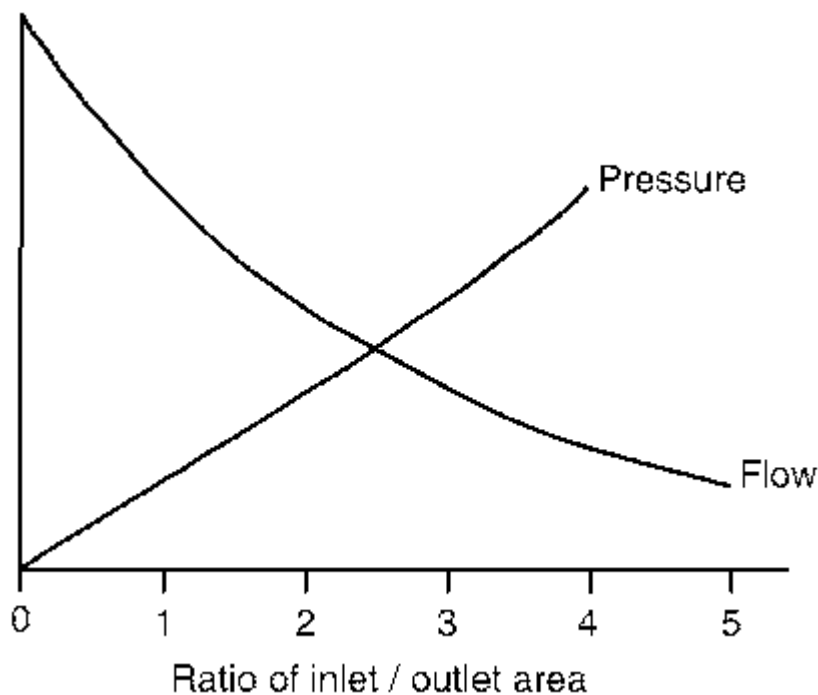

(See Figure 6.3)

If the inlet vent is also to be used as an entrance, the fan may cause an obstruction unless it can be placed a little way back, to allow access. However, this will reduce the proportion of the fan's air production which enters the building. If the fan is set 2 metres away from the door, typically the air flow through that door will reduce by 20%, and the internal pressure will reduce by 10%.

3 Positioning the Fan

Once the inlet vent has been selected, several factors will determine the location of the fan:

* The over-riding consideration will be that of access: if firefighters or escaping occupants need to use the door, the fan has to be set back to avoid obstructing the route.

* A secondary consideration will be whether the fan is to blow directly into the fire compartment. If this is the case, and turbulent mixing of the hot gases and smoke is undesirable, it may be better to set the fan back from the doorway. This will direct air in through the whole doorway, rather than part of it, and provide a more uniform flow in the compartment.

* Equally, if there is smoke but no fire in the compartment directly inside the doorway, it may be preferable to drive all the smoke into the building. Setting the fan back from the doorway will direct air in through the whole doorway, rather than part of it, and provide a more uniform flow in the compartment.

If the fan is moved back from the doorway, there will come a stage where the cone of air it produces covers the whole of the doorway.

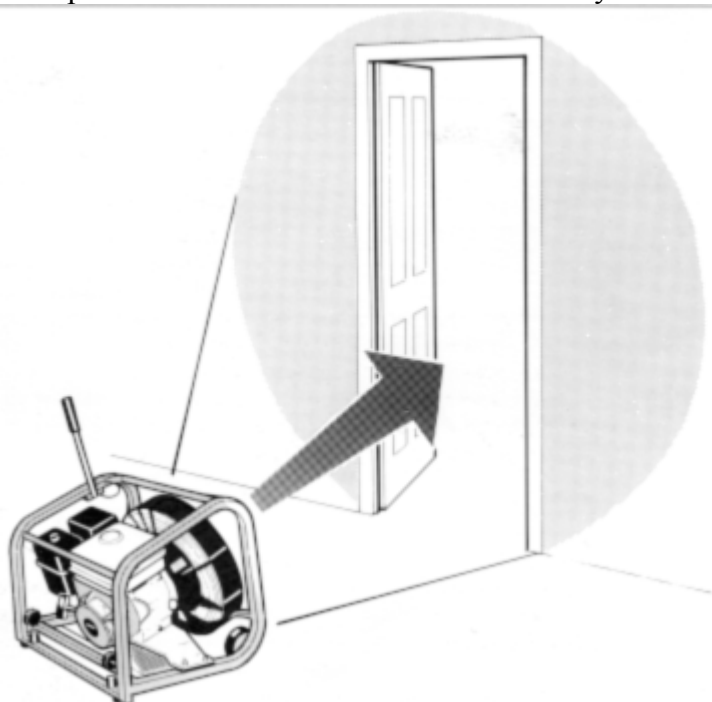

(See Figure 5.2) This reduces the amount of air which is entering the building, but makes most efficient use of the air which does go in. It aims to produce a moving wall of air to sweep all the smoke and hot gases before it in the direction of the outlet vent.

If there is no need to maintain access through the inlet vent the most efficient use of the fan is to place it in the doorway and to block off the rest of the doorway.

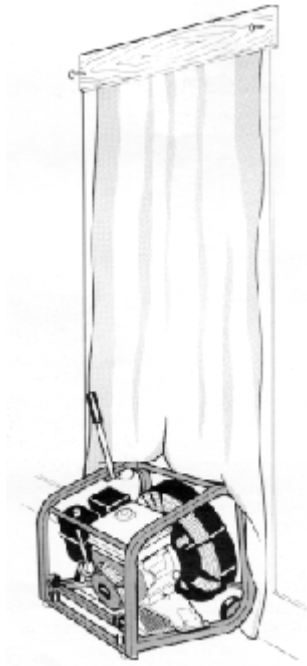

(See Figure 5.1)

4 Fighting an Opposing Wind

Wind strength and direction are usually the dominating factors in tactical ventilation. In most cases, it will determine the direction in which the smoke and hot gases will move within the building. Whenever possible, ventilation efforts should be in concert with existing atmospheric conditions, taking advantage of natural ventilation. However, in some situations, natural ventilation may be inadequate and may have to be supplemented or replaced by forced ventilation to provide a tenable atmosphere and to facilitate rescue operations.

The fact that a wind appears to be blowing in a particular direction out in the open, is no guarantee that it will be blowing in the same direction near buildings. They introduce unpredictable eddies, and local wind directions may reverse, and increase or decrease in magnitude significantly.

Before PPV is initiated, it is important to check that the wind at the proposed inlet and outlet vents is as expected.

If wind is blowing in through the proposed outlet vent, the PPV fan must be capable of producing an outlet velocity greater than the wind's inlet velocity, or the wind will win, the outlet vent will become an inlet vent and the inlet vent will become an outlet vent - an extra hazard to the firefighters there.

Since the outlet vent velocity which the fan can achieve increases as the outlet vent is reduced in size, a small outlet vent is preferable when there is an opposing wind.

* If the fan is blowing in through a doorway, and out through a window, the inlet to outlet ratio would be typically 2:1 and the outlet flow rate would be 3 cubic metres per second, corresponding to an outlet velocity of 3 metres per second, for a window

with a cross-section area of 1 square metre. A 3 metre per second (7 mph) wind would be classified as a gentle breeze, Force 2 on the Beaufort Scale.

* If the outlet is a small window, with a cross-section area of 0.5 square metres, the outlet velocity would be 6 metres per second (13 mph). A wind of this speed would be classified as a moderate breeze, Force 4 on the Beaufort Scale.

In many cases, advice to firefighters on the use of PPV is based on the principle 'if it doesn't work, you can always turn it off'. In this case however, once an outlet vent has been made on the upwind side of a building, it may not be possible to close it if things go wrong.

For this reason, the decision to try to use PPV to oppose a wind can have more far-reaching consequences, and should not be taken lightly.

Table 2 The Beaufort Scale

Beaufort Number	Wind	Wind Speed (m/s)	Wind Speed (mph)	Effect
0	Calm	0-0.4	0-1	Smoke rises vertically
1	Light Air	0.5-1.4	1-3	Direction shown by smoke, but not by wind vanes
2	Light Breeze	1.5-3.1	4-7	Wind felt on face; leaves rustle; wind vanes move
3	Gentle Breeze	3.2-5.4	8-12	Leaves and twigs in motion; wind extends light flag
4	Moderate Breeze	5.5-8.1	13-18	Raises dust, loose paper and moves small branches
5	Fresh Breeze	8.2-10.8	19-24	Small trees in leaf begin to sway
6	Strong Breeze	10.9-14.0	25-31	Large branches in motion; whistling in telephone wires; difficulty with umbrellas
7	Moderate Gale	14.1-17.0	32-38	Whole trees in motion; difficult to walk against wind
8	Fresh Gale	17.1-21.0	39-46	Twigs break off trees; progress impeded.

Table 2 The Beaufort Scale

5 Size and Location of the Fire Compartment

In a small building, it is generally possible to get access to the outside of the fire compartment. This means that, unless the wind is opposing, it is generally possible to make an outlet vent in the fire compartment. This keeps fire spread to the minimum when PPV is started.

In larger buildings, it may be difficult or impossible to identify the fire compartment immediately and PPV operations have to be delayed until this is done. Even then, it may not be possible to create an outlet vent very close to the fire. In very large compartments, it may be difficult to locate the fire within the compartment.

If portable PPV fans are used, they can only have a very limited capacity, and their effect will reduce drastically as the size of the fire compartment increases.

A typical flow-rate from a 24 inch blade diameter portable fan is 6 cubic metres per second (210 cubic feet per second). If set back from the door, perhaps only 5 cubic metres per minute will flow through the doorway.

* If air is flowing in through a doorway at a rate of 5 cubic metres per second. the air velocity through that doorway (cross-section of 2 square metres) will be about 2.5 metres per second.

* In a typical office corridor (cross-section 4 square metres), this will be reduced to 1.2 metres per second.

* In a typical workshop, hospital ward or small storage area (cross-section 30 square metres), the air velocity due to this one fan in the doorway will reduce to about 0.17 metres per second (17 centimetres per second). This may be too slow to be an acceptable rate of ventilation.

* In a typical supermarket (cross-section 60 metres wide by 5 metres high, giving an area of 300 square metres) the air velocity due to this one fan will reduce by a further factor of 10.

It is not yet possible to be specific about the air velocity which is effective at clearing smoke. It is clear, however, that single fans will not have any significant effect in large areas such as supermarkets and warehouses, although they may have some effect locally in doorways and corridors.

The most effective use of portable PPV fans is likely to be in clearing small compartments and corridors. Thus they may be particularly effective in domestic and small commercial premises, or in pressurising staircase enclosures.

In larger premises, a systematic room-by-room approach to smoke clearance will make best use of the limited air flow available.

6 The Effect of Opening Vents

Before it is opened up, the fire compartment will contain hot gases and smoke at ceiling level and, if these are very hot, they may have caused a pressure build-up inside the compartment. This pressure can be as high as 100 Pascals (1 millibar) compared to the pressure of at most 30 Pascals which the fan can generate. For a short period therefore, if the inlet vent is opened too soon after the outlet vent is opened, hot gases and smoke may flow out through the inlet vent, until the pressure inside has been reduced.

Even then, it may not be possible to completely seal a doorway with the cone of air from a fan. Inevitably, the main flow from a fan is along its axis and, although it may feel as though the top of the door is covered, the flow there will be much less, and the hot gases and smoke from the fire may be able to overcome it occasionally.

7 The Use of Multiple Fans

If the inlet vent is too large to be covered effectively by a single fan, or if a higher air flow rate is required, it is possible to use more than one fan in parallel (side by side).

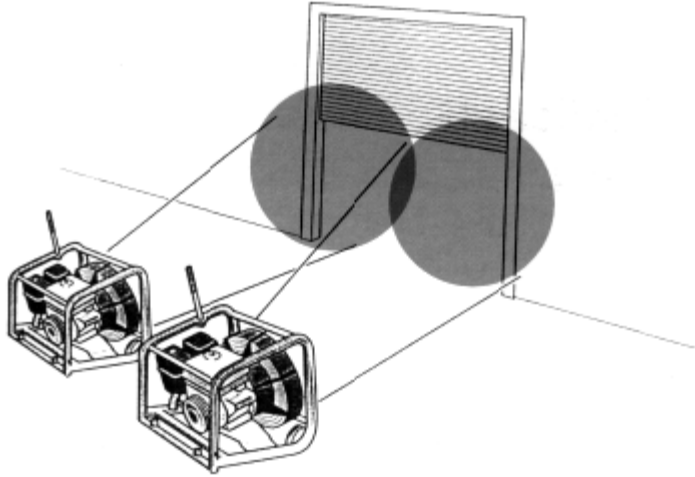

(See Figure 6.4)

If a higher airflow is required through a doorway, two fans can be used in series (or stacked), with one placed in the doorway, and the second placed behind it to provide the seal around the door.

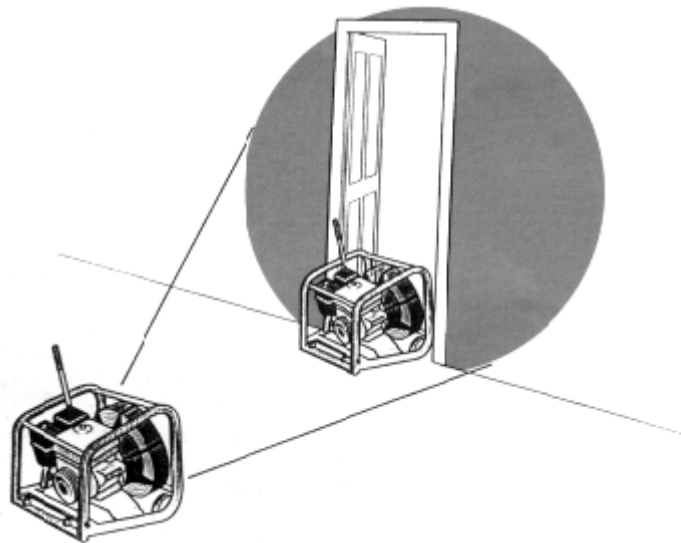

(See Figure 6.5) This, however, will restrict access through the doorway.

Where the building layout permits, more than one entry vent can be used but, in this case, extra care must be taken to ensure that one of the inlet vents does not become an outlet vent because of adverse wind conditions, or because the fans were not started up simultaneously.

Chapter 7 - Tactical Options with PPV: Defensive

1 Post Fire Smoke Clearance and Damping Down

During smoke clearance and damping down operations in a building it is usually the case that there will be considerable residual heat, hot spots or bullseyes with steam and smoke still being produced. Such an environment can make conditions uncomfortable and/or oppressive for firefighters.

The judicious use of positive pressure ventilation in these circumstances can help to relieve the above mentioned problems considerably.

The use of PPV in such circumstances does not necessarily mean that BA can be dispensed with, as smoke and gases may still be present in concentrations injurious to health.

The advantages of using PPV during smoke clearance and damping down operations are:

- * Rapid removal of smoke, steam and residual heat, improving visibility.
- * Cooler and easier working conditions when turning over debris.
- * Hot spots or bullseyes may become apparent due to the increased flow of fresh air. (Always have a hose reel or hose line available to deal with these)

The route the smoke/steam will take through the structure should be decided on before ventilation takes place. Any areas not affected should be isolated by closing relevant doors. The fan should be placed in position and started up only after other crew members have opened the exhaust vent. It is important that good communication is maintained between the fire ground commander, the fan operator and the crew at the exhaust vent.

The following sequence of operation should be followed:

- * Isolate unaffected areas where possible.
- * Position the fan.
- * Instruct crew members to open the exhaust vent.
- * Start the fan.
- * Check that the smoke/steam is taking the desired route to the exhaust vent and does not spread to other areas.
- * Continue to monitor the situation until PPV is discontinued.

In multi-compartmented buildings where smoke has spread to rooms other than the fire room, it may be desirable to ventilate sequentially. In this case the doors to all compartments, except the one to be ventilated initially, should be closed and the process begun. When that room is cleared of smoke, the door to the next room to be ventilated should be opened and an exhaust vent provided. The exhaust vent from the first room and the door to that room should then be closed. The process is repeated

until the building is cleared of smoke. It is advisable to commence operations in the compartment which was involved in the fire.

In multi-storey buildings, smoke clearance should commence at ground floor level, with the first floor being cleared next, and so on until the building is cleared.

2 Smoke Clearance as Part of Firefighting

It is possible to apply the tactics described above even before the fire is extinguished, provided that it is possible to ensure that the fire is totally isolated from the area where ventilation is to take place.

This may be appropriate where pressurisation of part of the building will prevent smoke from spreading into it, or where smoke has already spread into part of the building not involved in the fire, providing that it is possible to identify the route the smoke took, and it is possible to close this off.

This may be desirable if people are still present in the smoke-logged part of the building. Clearing the smoke will protect them from the effects of inhalation and will provide them with a clear escape route.

Such tactics may also prevent or mitigate the effects of smoke damage.

Chapter 8 - Tactical Options with PPV: Offensive

1 Domestic Premises

The air flows produced by portable PPV fans are eminently suitable for use in typical domestic premises if the wind is in the right direction. If the fire is on the ground floor and it is possible to create an outlet vent in the fire compartment, it is possible to use PPV to confine the fire to the fire compartment, whilst significantly improving conditions on the route from the inlet vent to the fire compartment. If smoke has spread through the rest of the premises, there may be sufficient spare capacity to apply systematic smoke clearance through the rest of the building.

If the fire is on the highest floor, it may take longer to create an outlet vent in the fire compartment. It may be necessary to use a ladder. It may be possible to use PPV to clear smoke on the ground floor at the same time as the upstairs fire is being fought.

If the fire is in the roof space, the only option with PPV may be vertical ventilation. It would then be necessary to remove tiles to create an outlet vent, before starting the fan. In terraced or semidetached buildings, the partition walls in the roof space may not provide a good seal, so it may be necessary to remove sufficient tiles to create a trench before starting the fan, to prevent fire spread. The use of PPV will cool the roof space significantly.

2 Stairwells

Not all stairwells in multi-occupancy dwellings are pressurised.

Where the stairwell has an open vent or window and is serving as the chimney for the hot gases and smoke, it is possible to use a PPV fan to dilute the gases in the stairwell by forcing a large amount of fresh air up the stairwell. It is important to avoid driving the hot gases and smoke out through some other route, so care must be taken not to pressurise the stairwell. This can be done by having as many outlet vents as possible above the fire floor.

If a new outlet vent can be made for the hot gases and smoke closer to, or in, the fire compartment, it may be preferable to use the PPV fan to pressurise the stairwell, and to drive the hot smoke and gases back and out through the new vent. This is achieved by minimising outlet vents in the stairwell. This will not remove smoke from the stairwell above the fire floor, but there may be sufficient spare capacity from the fan to apply systematic smoke clearance.

3 Corridors

PPV fans can be used where it is possible to select the direction of airflow in a corridor. The wind may be a determining factor in this but, where it is not, the fireground commander has the opportunity to make the choice.

If corridors link stairwells, it is possible to make one stairwell the outlet vent and to keep the other stairwell smoke-free.

4 Cellars

PPV fans are extremely effective at improving firefighting conditions in cellars, provided that it is possible to create an outlet vent. If there are removable pavement lights or stall boards, even on the up-wind side of the building, it may be possible to drive fresh air down the cellar steps. This will have the effect of reducing or even eliminating the hot layer on the steps, making the firefighter's job much easier.

It is unlikely that PPV alone will clear the smoke from a cellar. Ducting will probably be necessary once the fire is out. It can be used to direct the air in through the outlet vent to the far side of the compartment. This effectively creates an inlet vent at the far side of the compartment, and ventilation can then proceed as normal

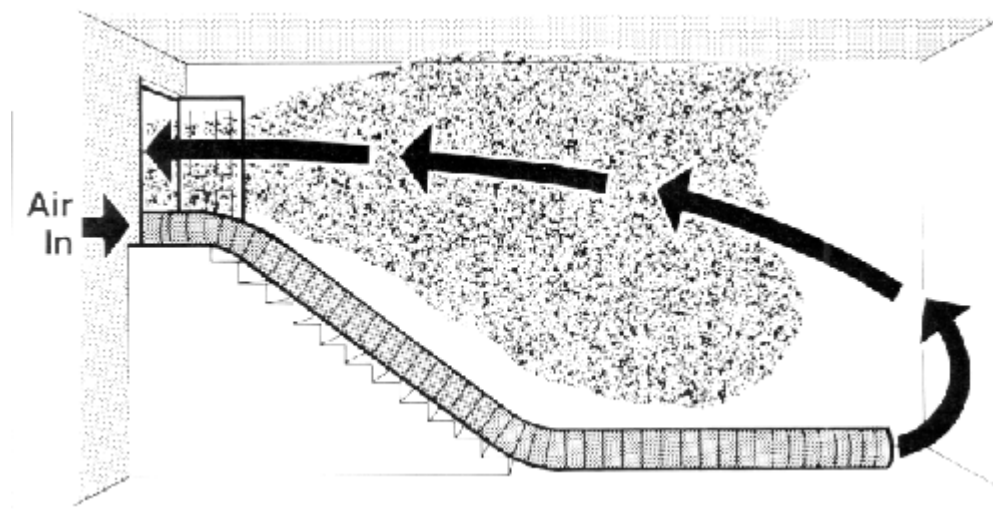

(See Figure 8.1) .

Care must be taken to ensure that any of the fan's air which is not being directed into the ducting, does not interfere with the flow out of the compartment. Care should also be taken to avoid recycling smoke through the fan feeding the duct, which should not be placed too near to the compartment door.

5 Small Workshops and Stores

As with any ventilation tactic, PPV should not be applied until it is certain that the location of the fire is known and that there is an outlet vent. Again the wind will be a significant factor. Where the fire compartment is not fully involved, and smoke logging is impeding firefighting, the use of PPV may make access easier and may help clear smoke in the compartment so that the fire can be found and fought.

The effectiveness of the tactic will be greatly influenced by the location of the outlet vent. Ideally, the outlet vent should be as close to the fire as possible. Otherwise, there will be fire spread along the route from the fire to the outlet vent. However, this may be preferable to fire spread behind the fire-fighters.

The limiting factor with this tactic is the relative sizes of the fan and the area to be cleared. With larger compartments it may prove necessary to increase the airflow beyond what can be achieved with one fan. If more than one fan is available, it may be useful either to use two inlet vents or to have one fan at the inlet vent, and to advance the second one to the entrance to the fire compartment.

6 Large Volumes

It is unlikely that portable PPV fans will have much effect in large compartments, although they may provide a slightly improved environment close to the inlet vent

Chapter 9 - Ventilation Scenarios

1 Single-Storey Warehouse/Industrial Building/Sports Hall

(a) Construction

The most common forms of construction are:

- * steel frame - a substructure of steel, supporting a corrugated steel or aluminium panelled roof, with walls part brick or block and part steel or aluminium wall panels;
- * brick or block walls with a wooden or metal trussed roof covered with plywood and bitumen.

Whatever type of construction is used, the roof may take on one of several forms, the most common of which are:

- * traditional pitched roof, of varying angles;
- * 'north light' or its modern equivalent;

* flat roof, self supporting, or internally supported.

In many cases, a major influence on the choice of ventilation technique is the lack of windows or doors for horizontal ventilation. If vertical ventilation is considered necessary, a wood-trussed structure may not be sufficiently robust for firefighters to be deployed on the roof to conduct defensive trench ventilation.

A single portable PPV fan is unlikely to have much effect in larger buildings of this type, unless the building has a number of internal compartments.

(b) Special Hazards

Most industrial/storage occupancies are large open areas with minimal sub-division and this can lead to rapid fire spread throughout the building.

Roof collapse, particularly in the case of lightweight truss roof constructions, can occur in a short period of time. In timber roof structures, this usually occurs where the bottom chord of the webbing has burnt through, or the nail plates have lost their grip. This can lead to progressive collapse of large areas of roof. Total failure of metal roof structures can occur at around 600°C, by when the steel has lost up to two thirds of its structural strength.

(c) Fire Against End Wall

Vertical ventilation is likely to be most effective. It may be possible to access the roof from outside the end wall, and to remove a section of roof very close to the fire. An initial hole two metres by one metre would be required, and this should be increased if the smoke is venting under pressure. The objective would be to have a large enough hole for the smoke to vent 'lazily'.

The inlet vents can be the doorways used for access by the firefighters, if the wind direction permits, or other doorways at ground level.

If it is impossible to produce a hole in the roof, it may be possible to create a high level hole in the wall.

(d) Fire in Centre of Building

Even if it is not possible to gain access to the roof near to the fire, it may still be possible to vertically ventilate, making a vent downwind, near to a wall, but fire-spread will occur in that direction.

Horizontal ventilation may be possible using a down-wind door or window as an outlet vent, but again fire spread will occur.

If it is possible to deploy firefighters safely on, or above, the roof, trenching downwind of the fire may reduce fire spread. The vent should be about one metre by two metres to begin with, and enlarged if the smoke and hot gases are venting under

pressure. A long, one metre wide vent is most effective at preventing fire spread past it.

(e) Unidentified Fire Location

It is generally wiser not to ventilate vertically until the location of the fire is known, although this should not preclude the use of horizontal ventilation, providing it is used correctly.

In both cases, there is always the risk of driving fire or smoke into areas which were previously clear, or even where people may be present.

2 Two-Storey Warehouse/Industrial Building/Sports Hall

(a) Construction

The most common forms of construction are similar to those used in single storey warehouses.

- * steel frame - a substructure of steel, supporting a corrugated steel or aluminium panelled roof, with walls part brick or block and part steel or aluminium wall panels;
- * brick or block walls with a wooden or metal trussed roof, covered with plywood and bitumen.

Whatever type of construction is used, the roof may take on one of several forms, the most common of which are:

- * traditional pitched roof, of varying angles;
- * 'north light' or its modern equivalent;
- * flat roof, self supporting, or internally supported.

In some cases, internal floors may offer little or no resistance to the passage of smoke or flame - for example, gantries or open mesh steel floors. Where this is the case, the whole building is a single compartment.

This may be complicated where a floor does not cover the full area of the building, The construction of the floor may allow smoke and hot gases to spread from a ground floor fire into the upper floor, whilst delaying vertical fire spread. This can be of great importance where mezzanine floors could provide a complex arrangement of smaller compartments.

This can be further complicated by the presence of a suspended ceiling, whether suspended beneath the roof, or on the ground floor, which may create additional voids not readily noticeable from outside.

(b) Fire on Ground Floor

It is important to establish whether the ground floor is an independent compartment. If it is, horizontal ventilation is the only practical option unless there are protected vertical shafts.

If the ground floor cannot be treated as an independent compartment, the entire building can be treated in the same way as a large single storey warehouse/industrial building.

(c) Fire on Upper Floor

This can be treated in the same way as a fire in a single storey warehouse/industrial building, except that there may be additional problems with access.

3 Small Commercial Units

(a) Construction

Once again, there are three basic types of construction:

- * monolithic concrete;
- * traditional (possibly converted) buildings;
- * lightweight.

(b) Fire Confined to Shop Unit

Where monolithic concrete construction has been used, horizontal ventilation, using existing doors and windows, is the only option unless roof lights are installed. There is unlikely to be fire spread between compartments.

With the more traditional buildings, it is important to consider the entire building, as separation between units is unlikely to be complete. Where there is residential accommodation above the commercial premises, means of escape from the upper storey may be the prime consideration.

Either horizontal or vertical ventilation may be practicable, depending on the design of the building. Although the traditional roof design of slates/tiles and timber lends itself to vertical ventilation, the location of the fire and the presence of ceilings may restrict the options for this technique.

4 Low Rise Apartment Buildings

(a) Construction

The construction of these buildings will vary widely, depending on date of construction and geographical location, from the 1930's stone tenement building, typical of Scottish inner cities, to the 1960's flat-roofed curtain-walled flats or maisonettes typical of re-housing schemes of that period.

Access to individual dwellings would typically be via an internal stairwell, perhaps linked by open-deck or balcony access.

Where the building has been well maintained, a degree of separation between dwellings can be assumed, although this may not extend to the roof void.

(b) Fires in Accommodation Units

Means of escape for the residents has to be given the highest priority, and the pressurisation of stair-wells using PPV may simplify the evacuation of large buildings

Also, where fire has spread to more than one dwelling, ventilation can materially assist fire-fighting operations by improving access.

There are cases where the use of ventilation can be considered even before the location of the fire is known.

Where the stairwell is smoke-logged, positive pressure ventilation can be set up, driving air in through the doorway. In the event of built-in outlet vents not being available, firefighting teams will then need to work progressively up the stairwell opening vents floor by floor, and closing them again when it is clear up to that level

Within a dwelling, horizontal ventilation is the only viable option, possibly by breaking windows from outside.

5 Two-Storey Residential House

(a) Construction

The size and construction of such buildings, and their proximity to their neighbours can vary so widely that it is impossible to generalise.

Modern building standards, however, are leading to better insulation levels. This can result in a reduced air supply to any fire and the consequential risk of oxygen depletion. At the same time, the fire load is increasing with the greater use of synthetic materials and fitted carpets.

These two factors combine to provide an increasing risk of backdraught in residential properties.

(b) Fire on Upper Level

Roof and ceiling construction will determine whether vertical ventilation is a realistic option. If the fire has not reached the roof void, it should NOT be encouraged to do so! In terraced houses, this can be a major source of fire spread to adjoining properties.

Horizontal ventilation may be most effectively achieved by opening or breaking windows, provided this can be done safely.

Alternatively, suitable outlet vents can be created as appropriate, and the stairwell pressurised from below.

(c) Fire on Lower Level

Natural horizontal ventilation can be very effective, and pressurisation may be of value where inlet and outlet vents have to be on the same side of the building, or to prevent smoke and hot gases rising to the upper storey.

Chapter 10 - Basements, Underground Structures and Tunnels

1 Introduction

The main difficulty in fighting underground fires is in creating a route out for the smoke and hot gases which is separate from the access route. Where this can be achieved, forced ventilation can be extremely successful.

When fighting fires in tunnels, however, this may not be possible, notably in 'dead-end' or 'blind-heading' tunnels. In such situations, safe and successful operations depend on particularly well planned breathing apparatus procedures and fire-fighting tactics, with reliable communications and, in some cases, hand-held environmental monitoring equipment. For greater detail in relation to breathing apparatus procedures in deep penetration situations, reference should be made to specific Home Office guidance, notably Technical Bulletin 1/1993 - Operational Incidents in Tunnels and Underground Structures.

2 Basements

In basements where pavement lights or stall board lights exist, these can sometimes be used as the outlet vent in conjunction with Positive Pressure Ventilation

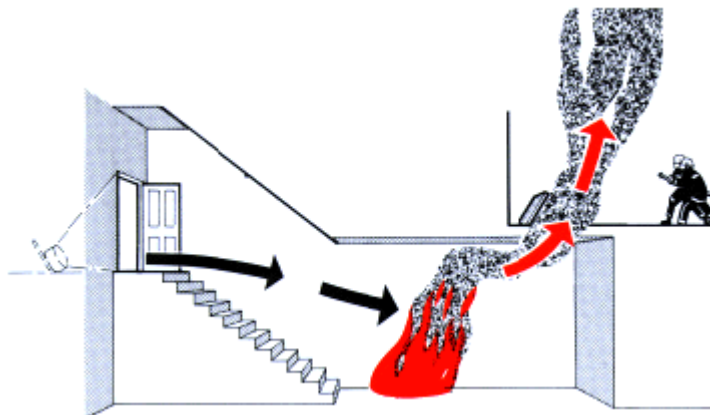

(See Figure 10.1) .

Firefighting can be made much safer if this technique can be used before firefighting teams are committed, as it will reduce the total heat in the compartment. It can sometimes eliminate the 'heat barrier' in the stairway entirely, reducing heat stress on the firefighter and reducing the risk of scalding when water is applied.

Note, however, that, in built up areas, it can be difficult to be certain of wind directions, and adverse conditions could worsen conditions in the basement and approach stairs.

3 Tunnels

(a) General Considerations

Fires in tunnels are rare occurrences, but people planning and operating tunnels need to prepare for all eventualities.

Smoke movement from a fire is often considered as part of the initial tunnel design. In some cases, there will be shafts to the surface at intervals along the tunnel length, allowing smoke to escape. Often fixed ventilation systems will be provided to supply fresh air for people and vehicles, and these too can take smoke out of the tunnel. Tunnels may have 'transverse' systems where fresh air enters the tunnel and stale air is extracted along the whole length, eventually flowing out of either end, and in others air may simply be blown from one end of the tunnel to the other in a 'longitudinal' system.

(b) Smoke Movement in Tunnels

For a typical small compartment fire, the hot gases and smoke will rise to the ceiling and spread over the roof, gradually filling the compartment. In a tunnel, the ceiling space is, at least initially, far too large to be filled by the smoke.

Left to itself, the smoke and hot gases will spread along the tunnel roof in both directions. Longitudinal ventilation can control the flow of smoke, pushing it all in one direction. If the ventilation air flow is too slow, the hot smoke and gases can push upstream against the main air flow, a phenomenon known as 'back-layering'. This upstream hot layer will stop once it has cooled down sufficiently for the force of the ventilation air to overcome the buoyant forces remaining in the cooled gases.

Down-stream, the hot gases and smoke will travel long distances at roof level, with the layer dropping as it cools. If it cools to the ambient temperature, the gases and smoke will drop to floor level causing a smoke plug

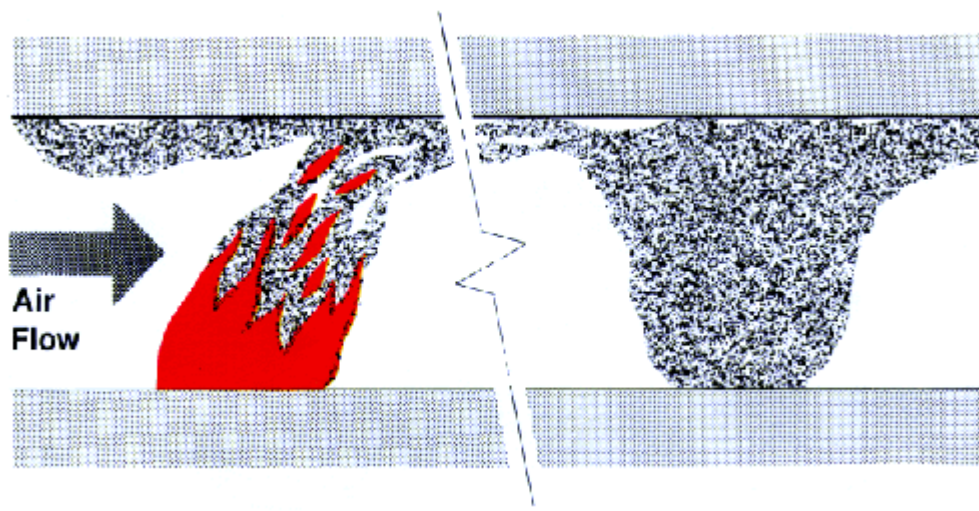

(See Figure 10.2) .

If the air supply to the fire is coming from the same end as the one from which the hot gases and smoke are escaping, this smoke plug will be drawn back into the tunnel along with the fresh air supply, eventually smoke-logging the tunnel if the production of smoke is maintained.

(c) Fires on Trains or Vehicles in Motion

Where fires occur on trains or vehicles in motion, a progressive release of smoke into the tunnel airflow may become mixed in the turbulence created by the movement itself and cause a general 'fogging' rather than the stratification created by a stationary fire. In such circumstances, the degree of mixing of the smoke in the volume of air in the tunnel may be considerable and, assuming that the train or vehicle has stopped, light smoke may exist at a great distance from the incident, with the smoke plug becoming progressively denser nearer to the fire.

(d) Tunnels under Construction

Tunnels under construction have yielded a significant number of serious fires and present particular difficulties. Where 'dead-end' or 'blind-heading' conditions exist in long tunnels, fresh air is normally carried to the cutting face and construction area or boring machine in lightweight extendible ducting. Such ducting will be likely to be suspended from a high point in the tunnel roof to be clear of moving machinery and vehicles.

Providing this ducting remains intact, air reaching the dead end of the tunnel will push a smoke plug back along the tunnel towards fresh air. However, the air flow may be such that movement is slow, given that the air arriving through a 1m diameter duct, for example, may have to push back a smoke plug in a tunnel of say 6m diameter. Although movement is slow, the pressurisation of the zone beyond the plug with fresh air can produce a 'smoke wall' effect in which the receding smoke plug retains a broadly vertical profile with virtually no mixing at the interface with the clean air.

In situations where ducting has been damaged by the fire, a judgement will need to be made about whether ventilation should be left on or turned off. Where no persons are reported, the decision should be based upon the materials involved in the fire, if known. If, for example, the fire is known to involve a vehicle, a quantity of materials, or some specific piece of plant used in the tunnel construction, it is probably preferable to leave ventilation running, even where its supply ducting has been damaged, in order to retain some air movement and therefore smoke movement away from the incident.

Once the fire has been extinguished, or burned itself out before extinguishing media could be applied, it may be possible to replace or temporarily repair a damaged section of ducting in order to restore the airflow to the dead end, and begin pushing the smoke plug out of the tunnel.

Where pressurised workings are involved, special considerations are necessary and full consultation must take place with the contractors.

(e) Ventilation Options

Firefighters will need to be fully aware of the built-in safety features of the tunnel, and to make full use of them. Automatic ventilation systems may be installed, and protected access routes may be available.

If pre-installed systems are not available, it is unlikely that portable systems would be powerful enough to have a significant effect in any tunnel larger than a typical corridor. Natural ventilation will be the only option.

The same principles will then apply. An inlet and an outlet vent will have to be selected, together with a route between them. Effective ventilation will cause an improvement in the firefighting conditions near the fire, whilst misuse could result in insignificant fire growth.

Chapter 11 - High Rise Buildings and Malls

Introduction

With the high prices demanded for land in inner cities, the trend has been to build up rather than out. In the 1960's this principle was applied to residential premises but, more recently, the trend has been towards high-rise commercial premises.

This same trend has led to an increase in the number of underground structures, particularly to meet requirements for car parking.

Hot gases will rise via lift shafts, staircases, and any other path which may be available carrying with them smoke, flame and burning materials. If they cannot escape by way of a vent, they will mushroom out under the ceilings and roofs that confine them

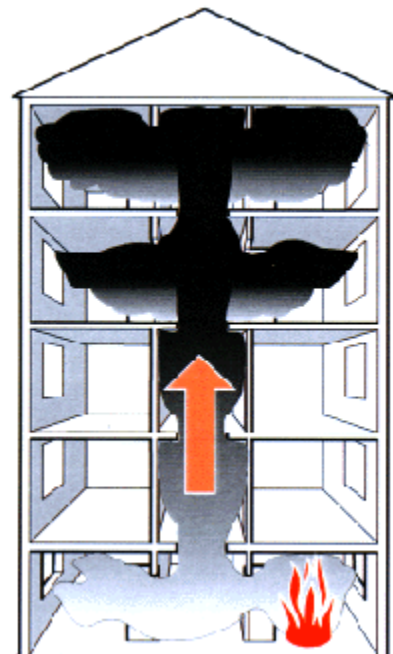

(see Figure 11.1) . In this way the fire may spread to other, hitherto unaffected areas; mushrooming is in fact one of the most common causes of fire spread through roof spaces or from floor to floor.

For this reason United Kingdom fire legislation has placed many constraints on the designs of such buildings, in some cases requiring, amongst other features, smoke extraction systems designed to prevent escape routes from becoming smoke-logged, and to limit smoke travel between storeys.

In high-rise commercial structures, architects have tended to design imposing ground floor areas, with atria often rising many storeys inside the building, and sometimes through the whole height of the structure.

In large atria, which can develop climates of their own, even resulting in rain clouds forming, air conditioning systems are essential, becoming in effect climate control systems.

Stairwells will sometimes extend for the full height of the building, especially in older property, and be provided only with single fire resisting doors leading from them. In the majority of high rise buildings however, there will be lobbies, fire resisting doors and/or pressurisation used to keep the stairwell clear of smoke in case of fire.

2 The Stack Effect

One of the problems associated with having an undivided stairwell in a high rise building is that it can act as a chimney stack

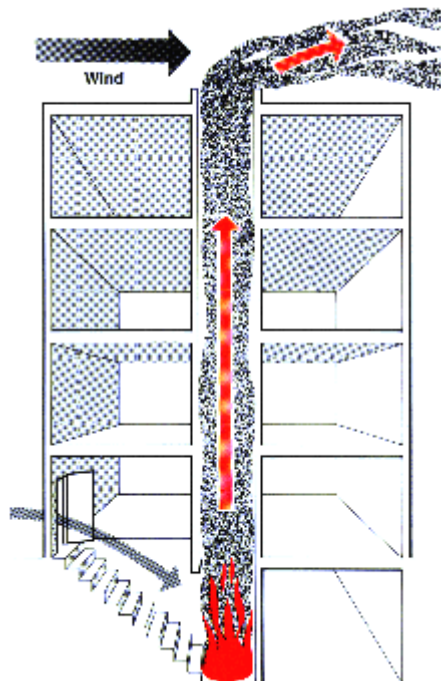

(See Figure 11.2) and allow the products of combustion to rise throughout its height and so risk spread of fire to other floor levels. It is therefore important that any fire resisting doors fulfil the function for which they were intended.

When a fire occurs, very hot smoke and gases can rise very rapidly. As these gases rise, they mix with cooler air and will, provided the air reservoir is large enough, cool to the same temperature as the surrounding air. When this happens, the smoke and gases cease to rise and may build up a smoke layer at high level

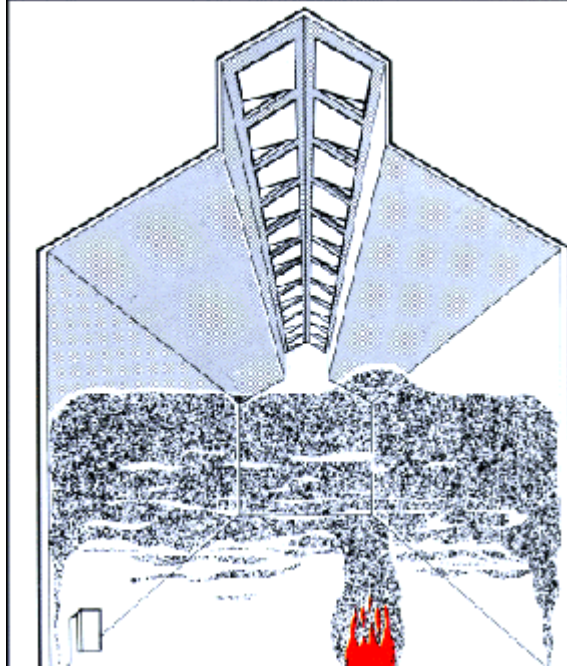

(See Figure 11.3) . The smoke may then sink and cause smoke logging to become more dense. Any smoke extraction system would need to be designed to counteract this effect.

Where there is not a large reservoir of cool air at high level in the building, the smoke and gases may retain their heat and continue to rise. Ultimately, there will be an airflow out through the highest natural vent, as long as the air temperature outside the building is lower than the temperature of the smoke and gases. If there is an inlet at low level and a suitable outlet at high level, quite high vertical velocities can result. These will depend on the height of the stack and the temperature of the smoke and gases.

This effect can be used to draw air, smoke and hot gases up through a stairwell, and is useful as a means of vertical ventilation. It should not be used in stairwells likely to be required as escape routes from higher storeys. Care must be taken that the products of combustion are not allowed to spread from the stairwell to other parts of the building.

The stack effect can be unpredictable, as it depends on so many factors. The Officer-in-Charge will need to base the firefighting tactics on the situation as it develops.

3 Firefighting in High-Rise Structures

It is not intended in this Manual to deal with all aspects of firefighting operations, but there are certain factors relating to tactical ventilation operations which are relevant.

When firefighting operations are being initiated from the floor below the fire, it must be remembered that, in gaining access to the fire, firefighters are opening a route

which may serve as an inlet or outlet vent. Such routes must be controlled as accidental venting may result in worsening conditions.

Breaking windows on high rise buildings can endanger firefighters and the general public below. Broken glass may travel considerable distances sideways when falling from a height, especially in a strong wind. Appropriate safety precautions must be taken before windows are deliberately broken.

4 Built-In Smoke Ventilation Systems

Such systems are described in the Manual of Firemanship Book 9.

In using such a system as part of planned tactical ventilation during firefighting operations, it must be remembered that the system is likely to be automatic in operation and will probably have begun to function before the arrival of the fire brigade.

It must not be assumed that such systems are installed primarily for the use of firefighters. Their primary use may be in the day-to-day operation of the building. For example, in industrial premises, a ventilation system may be designed to assist in providing acceptable working conditions for the employees. The provision of a high level exit route for smoke and hot gases, helping to prevent the spread of fire, might be only a secondary consideration in its design.

5 The Effects of Wind

In high-rise buildings, the effect of winds can be far higher than in low-rise buildings. The wind speed generally increases with height. Thus a 5 metre per second wind at ground level might correspond to a 10 metre per second 10 storeys up, and a 13 metre per second wind 20 storeys up.

A wind creates high pressure on the upwind side of a building and low pressure on the downwind side.

This can have a significant effect on the stack effect, depending on the location of the outlet vent. If the outlet is on the side of the building facing into the wind, it may prove impossible for the hot smoke and gases to escape, as the high pressure due to the wind may prove stronger than the buoyancy effect of the hot gases. Alternatively, if the outlet faces down wind, the stack effect may be increased by the presence of the negative pressure. If the outlet is on the top of the building, the effect of the wind passing across it may again be to increase the stack effect.

Strong winds outside a building at high level can have a dominant effect in ventilation. Opening vents to provide horizontal ventilation may result in a near gale blowing through the building. In some circumstances, and if not properly controlled, this could result in serious fire growth and spread.

In the fire compartment, the integrity of the windows may be seriously reduced by the heat. Opening the compartment door may then cause the windows affected to break. If the wind is blowing into the window and there is a suitable outlet vent beyond the

open door, a backdraught could occur or, alternatively, there could be a blowtorch effect at the door

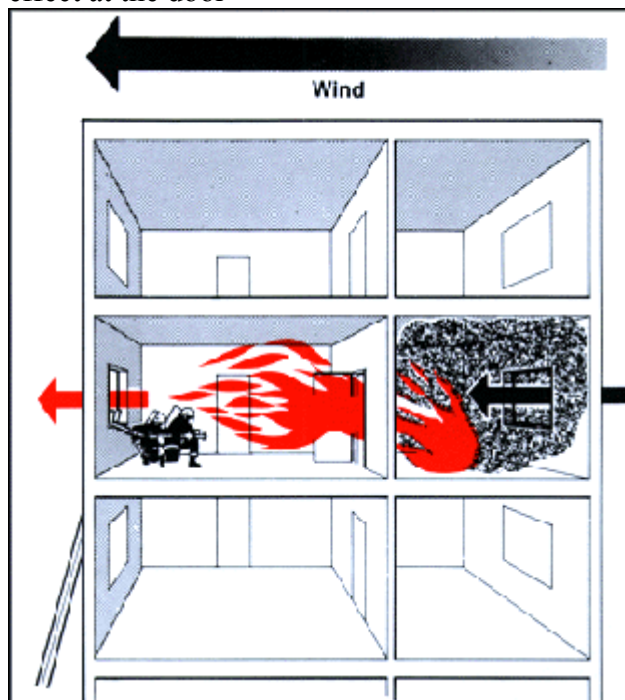

(See Figure 11.4), or even at more remote points on the access route. Either event would be extremely dangerous to firefighters at, or outside, the door. Wind produces a positive air pressure on the upwind face of a building, and a negative pressure on the downwind face of the building. This can be used to advantage in planning tactical ventilation.

Before the fire floor is ventilated, it is essential to be sure that the resulting air movements will be appropriate for effective, safe ventilation. If the compartment is on the windward side, the removal or opening of windows will result in the smoke and hot gases being driven into the building. If the compartment is to leeward, the smoke and hot gases will be drawn out.

6 Ventilation below the Fire

This may be necessary where cool smoke has spread downwards or where no other form of ventilation is viable. It should be borne in mind that tactical ventilation between floors will compromise passive fire safety measures simply because any doors between floor levels must be held open in order to complete a route to open air for the smoke.

It is important to ensure, whenever possible, that the inlet vent is at the lower level, and the outlet vent at the upper level, to prevent hot gases being forced to the floor below and causing fire spread or a backdraught. The problems associated with the movement of the products of combustion should be fully appreciated before this type of ventilation is begun.

7 Ventilation above the Fire

This tactic may be required where there has been significant spread of hot smoke and gases above the fire floor. The primary objective of ventilation would be to ensure the safe escape of any persons remaining in the premises, but an equally important objective would be to minimise the possibility of a backdraught if there has been a build-up of flammable gases anywhere.

In order to reduce the inherent risks of backdraught and fire spread, it is important to ventilate any spaces containing hot flammable gases as a priority. Even if these gases are not already at their auto-ignition temperature, the risk of backdraught will still be present if fresh air and a source of ignition are introduced.

Where gases are at their auto-ignition temperature, the introduction of a fresh air supply may be sufficient to cause a backdraught. It is important therefore, to identify where hot smoke and gases are accumulating. The most likely places are the floor level immediately above the fire if stopping between floors is breached or inadequate, or at the top of unventilated vertical shafts such as stair-wells or lift shafts.

8 Ventilation of the Fire Floor

As always, knowledge of the building layout is essential. Depending on the layout, either horizontal or vertical ventilation may be possible.

Provided the stack effect can be induced, it may be possible to ventilate vertically by using a stairwell or other vertical shaft. However, where the vertical space is too high or large, when compared with the size of the fire, this may result in smoke logging at levels below the vent to open air.

In some circumstances, it may be possible to use one stairwell as the inlet vent, pass air through the fire compartment and out through another stairwell to open air. In such cases, it would be advantageous to maintain a positive pressure in the inlet stairwell, either by use of internal systems or by using portable fans. The pressure in the outlet stairwell would need to be reduced if possible, and any internal pressurisation system switched off. An operation of this kind needs to be very carefully controlled as it compromises both staircases.

The most likely option would be the use of horizontal ventilation, opening selected windows and/or doors to produce a controlled airflow through the area to be ventilated. As stated previously, care would have to be taken not to have too strong an airflow in order that the fire situation is not made worse. This may involve having a small inlet vent on the upwind side of the building and a larger vent on the downwind, reduced pressure, side of the building.

Negative Pressure Ventilation (NPV) using fans or water sprays at a downwind opening may help to augment or accelerate the horizontal ventilation.

Chapter 12 - Summary

Summary

The objective of ventilation at a fire is to remove heated air, smoke and other airborne contaminants from a building, and to replace them with fresher air.

Ventilation can be used as a tactical option during firefighting.

Properly used, it can have significant beneficial effects on firefighting:

- * it can assist escape by restricting the spread of smoke on escape routes, improving visibility and extending available egress times;
- * it can aid rescue operations by reducing the smoke and toxic gases which hinder search activities and endanger trapped occupants;
- * it can improve the safety of firefighters by reducing the risk of flashover, and making it easier to control the effects of a backdraught;
- * it can speed attack and extinguishment by removing heat so that firefighters can enter a building early and, by removing smoke and improving visibility, make it easier for fire-fighters to locate and deal with the fire;
- * it can reduce property damage where the fire can be located and tackled more quickly and, by limiting the movement of smoke and hot gases, restrict fire spread.

INCORRECTLY APPLIED, IT CAN INITIATE BACKDRAUGHTS, CAUSE FIRE SPREAD AND PLACE FIREFIGHTERS AT RISK.

The basic principles in commencing ventilation can be summarised in a simple checklist:

- 1 Identify the purpose of the ventilation. This will determine whether the approach is to be offensive or defensive.
- 2 Ensure that there is effective communication between firefighters performing other activities inside the building, the Officer-in-Charge and those firefighters inside and outside the building who will be conducting the various ventilation activities.
- 3 Identify the wind direction.
- 4 Decide whether to adopt vertical or horizontal ventilation.
- 5 If the wind will not provide sufficient ventilation on its own, once the vents have been made, consider whether forced ventilation may help.
- 6 Select the locations of the inlet and outlet vents, and decide how they are to be made.
- 7 Arrange for the outlet vent or vents to be covered by manned charged hoselines.
- 8 Consider whether firefighters inside the building need to be withdrawn whilst ventilation takes place. If so, withdraw them.

9 Notify all concerned of the intention to start ventilation.

10 Make the outlet vent first. This may result in an initial fireball.

11 If the inlet vent is also the firefighter's point of access, no further action may be necessary. Otherwise, once any initial effects have occurred, make the inlet vent.

12 If being used, start up the PPV/NPV fan.

The effects of the ventilation must be closely supervised, and the progress inside the building must be reported to the Officer-in-Charge.

Aide Mémoire 3

Tactical Ventilation

- * NOTE AND USE THE PREVAILING WIND.
- * CONSIDER THE SITUATION CAREFULLY AND SELECT THE APPROPRIATE TACTIC.
- * CONSIDER WHETHER FIREFIGHTERS INSIDE NEED TO BE WITHDRAWN WHILST VENTILATION TAKE PLACE.
- * OUTLET VENT FIRST, HIGH AND DOWNWIND.
- * COVER OUTLET VENT(S) WITH CHARGED HOSE LINE(S).
- * START INLET VENTING ALMOST IMMEDIATELY AFTER OUTLET VENT HAS BEEN MADE.
- * ENSURE EFFECTIVE COMMUNICATION BETWEEN OFFICER-IN-CHARGE, ALL IN THE BUILDING, AND THOSE CARRYING OUT VENTILATION ACTIVITIES.
- * CONSTANTLY MONITOR THE EFFECTS OF VENTILATION. KEEP OFFICER-IN-CHARGE INFORMED OF INTERNAL PROGRESS.

Glossary of terms

VENTILATION

the removal of heated air, smoke and other airborne contaminants from a structure, and their replacement with a supply of fresher air.

SELF VENTILATION

occurs when the fire damages the structure so that increased ventilation occurs.

AUTOMATIC VENTILATION

occurs when pre-installed vents are activated automatically, usually in the early stages of the fire, by the fire detection system or fusible link devices.

TACTICAL VENTILATION

requires the intervention by the fire service to open up the building, releasing the products of combustion and allowing fresher air to enter.

VERTICAL (OR TOP) VENTILATION

making an opening at high level, (usually through the roof) such that the buoyancy of the hot gases and smoke enables them to escape vertically.

HORIZONTAL (OR CROSS) VENTILATION

making openings in the external walls (for example using windows and doors) so that the wind assists in the removal of the hot gases and smoke.

NATURAL VENTILATION

describes collectively the techniques of vertical and horizontal ventilation when they are not assisted by mechanical means. This includes the use of pre-installed vents, windows, doors etc.

FORCED VENTILATION

describes collectively the techniques of vertical and horizontal ventilation when mechanical means are used to assist in removing the hot gases and smoke, or in providing a supply of fresh air.

OFFENSIVE VENTILATION

ventilating close to the fire to have a direct effect on the fire itself, to limit fire spread, and to make conditions safer for the firefighters.

DEFENSIVE VENTILATION

ventilating away from the fire, or after the fire is out, to have an effect on the hot gases and smoke, particularly to improve access and escape routes and to control smoke movement to areas of the building not involved in the fire.

POSITIVE PRESSURE VENTILATION (PPV)

PPV can be achieved by forcing air into a building using a fan. The effect of this will be to increase the pressure inside, relative to atmospheric pressure. PPV simply refers to blowing air in through the inlet vent.

NEGATIVE PRESSURE VENTILATION (NPV)

NPV refers to extracting the smoke and hot gases from the outlet vent. This will have the effect of reducing the pressure inside the building, relative to the atmospheric pressure. It can be achieved by fans or water sprays.

Further Reading

Dear Chief Officer Letter 14/1985 (Dear Firemaster Letter 9/1985). The Use of Smoke Extracting Equipment in Fire Brigade Operations - Research Report 26.

Technical Bulletin 1/1993. Operational Incidents in Tunnels and Underground Structures. HMSO.

International Fire Service Training Association - Fire Ventilation Practices - Seventh Edition. Fire Protection Publications, Oklahoma State University.

H P Morgan and J P Gardner - Design Principles for Smoke Ventilation in Enclosed Shopping Centres. BRE Report BR186 1990.

British Standard BS 5588: Fire Precautions in the Design, Construction and Use of Buildings.

Dear Chief Officer Letter 9/1997 which provides details of Training Videos produced to complement this publication.